

Set-2

Series DAA1B/3

प्रश्न-पत्र कोड  
Q.P. Code

31/3/2

रोल नं.   
Roll No.



परीक्षार्थी प्रश्न-पत्र कोड को उत्तर-पुस्तिका के मुख-पृष्ठ पर अवश्य लिखें।

Candidates must write the Q.P. Code on the title page of the answer-book.

## विज्ञान SCIENCE

निर्धारित समय : 3 घण्टे

Time allowed : 3 hours

अधिकतम अंक : 80

Maximum Marks : 80

नोट	NOTE
(I) कृपया जाँच कर लें कि इस प्रश्न-पत्र में मुद्रित पृष्ठ 31 हैं।	(I) Please check that this question paper contains 31 printed pages.
(II) कृपया जाँच कर लें कि इस प्रश्न-पत्र में 39 प्रश्न हैं।	(II) Please check that this question paper contains 39 questions.
(III) प्रश्न-पत्र में दाहिने हाथ की ओर दिए गए प्रश्न-पत्र कोड को परीक्षार्थी उत्तर-पुस्तिका के मुख-पृष्ठ पर लिखें।	(III) Q.P. Code given on the right hand side of the question paper should be written on the title page of the answer-book by the candidate.
(IV) कृपया प्रश्न का उत्तर लिखना शुरू करने से पहले, उत्तर-पुस्तिका में प्रश्न का क्रमांक अवश्य लिखें।	(IV) Please write down the serial number of the question in the answer-book before attempting it.
(V) इस प्रश्न-पत्र को पढ़ने के लिए 15 मिनट का समय दिया गया है। प्रश्न-पत्र का वितरण पूर्वाह्न में 10.15 बजे किया जाएगा। 10.15 बजे से 10.30 बजे तक परीक्षार्थी केवल प्रश्न-पत्र को पढ़ेंगे और इस अवधि के दौरान वे उत्तर-पुस्तिका पर कोई उत्तर नहीं लिखेंगे।	(V) 15 minute time has been allotted to read this question paper. The question paper will be distributed at 10.15 a.m. From 10.15 a.m. to 10.30 a.m., the candidates will read the question paper only and will not write any answer on the answer-book during this period.

2231/3/2

112 B

1

P.T.O.

सामान्य निर्देश :

निम्नलिखित निर्देशों को सावधानी से पढ़िए और उनका सख्ती से पालन कीजिए :

- (i) इस प्रश्न-पत्र में कुल 39 प्रश्न हैं। सभी प्रश्न अनिवार्य हैं।
- (ii) यह प्रश्न-पत्र पाँच खण्डों में विभाजित किया गया है – क, ख, ग, घ एवं ङ।
- (iii) खण्ड क – प्रश्न संख्या 1 से 20 तक बहुविकल्पीय प्रकार के प्रश्न हैं। प्रत्येक प्रश्न 1 अंक का है।
- (iv) खण्ड ख – प्रश्न संख्या 21 से 26 तक अति लघु-उत्तरीय प्रकार के प्रश्न हैं। प्रत्येक प्रश्न 2 अंकों का है। इन प्रश्नों के उत्तर 30 से 50 शब्दों में दिए जाने चाहिए।
- (v) खण्ड ग – प्रश्न संख्या 27 से 33 तक लघु-उत्तरीय प्रकार के प्रश्न हैं। प्रत्येक प्रश्न 3 अंकों का है। इन प्रश्नों के उत्तर 50 से 80 शब्दों में दिए जाने चाहिए।
- (vi) खण्ड घ – प्रश्न संख्या 34 से 36 तक दीर्घ-उत्तरीय प्रकार के प्रश्न हैं। प्रत्येक प्रश्न 5 अंकों का है। इन प्रश्नों के उत्तर 80 से 120 शब्दों में दिए जाने चाहिए।
- (vii) खण्ड ङ – प्रश्न संख्या 37 से 39 तक 3 स्रोत-आधारित/प्रकरण-आधारित इकाइयों के मूल्यांकन के 4 अंकों के प्रश्न (उप-प्रश्नों सहित) हैं।
- (viii) प्रश्न-पत्र में समग्र विकल्प नहीं दिया गया है। यद्यपि, कुछ खण्डों में आंतरिक विकल्प दिए गए हैं। इस प्रकार के प्रश्नों में केवल एक ही विकल्प का उत्तर दीजिए।



## General Instructions :

*Read the following instructions very carefully and strictly follow them :*

- (i) *This question paper consists of 39 questions. All questions are compulsory.*
- (ii) *This Question paper is divided into five sections – A, B, C, D and E.*
- (iii) *Section A - Question Nos. 1 to 20 are Multiple Choice Questions. Each question carries 1 mark.*
- (iv) *Section B - Question Nos. 21 to 26 are Very Short Answer type questions. Each question carries 2 marks. Answer to these questions should be in the range of 30 to 50 words.*
- (v) *Section C - Question Nos. 27 to 33 are Short Answer (SA) type questions. Each question carries 3 marks. Answer to these questions should be in the range of 50 to 80 words.*
- (vi) *Section D - Question Nos. 34 to 36 are Long Answer type questions. Each question carries 5 marks. Answer to these questions should be in the range of 80 to 120 words.*
- (vii) *Section E - Question Nos. 37 to 39 are of 3 source-based/case-based units of assessment carrying 4 marks each with sub-parts.*
- (viii) *There is no overall choice. However, an internal choice has been provided in some sections. Only one of the alternatives has to be attempted in such questions.*



इस खण्ड में 20 बहुविकल्पी प्रश्न (प्रश्न 1 – 20) हैं। सभी प्रश्न अनिवार्य हैं।

1. काँच, साबुन और कागज उद्योगों में उपयोग होने वाला रासायनिक यौगिक है 1
  - (A) धोने का सोडा
  - (B) बेकिंग सोडा
  - (C) विरंजक चूर्ण
  - (D) साधारण नमक
  
2. नीचे दी गयी कौन सी एक अभिक्रिया अन्य तीन अभिक्रियाओं से भिन्न है ? 1
  - (A)  $\text{NaCl} + \text{AgNO}_3 \rightarrow \text{AgCl} + \text{NaNO}_3$
  - (B)  $\text{CaO} + \text{H}_2\text{O} \rightarrow \text{Ca(OH)}_2$
  - (C)  $\text{KNO}_3 + \text{H}_2\text{SO}_4 \rightarrow \text{KHSO}_4 + \text{HNO}_3$
  - (D)  $\text{ZnCl}_2 + \text{H}_2\text{S} \rightarrow \text{ZnS} + 2\text{HCl}$
  
3. नीचे दी गयी रासायनिक अभिक्रिया में प्राप्त उत्पाद 'X' पहचानिए : 1

$$\text{CaCO}_3 \xrightarrow{\Delta} \text{'X'} + \text{CO}_2$$
  - (A) बिना बुझा चूना
  - (B) जिप्सम
  - (C) चूना पत्थर
  - (D) प्लास्टर ऑफ पेरिस
  
4. निम्नलिखित में से प्राकृतिक सूचकों का जोड़ा चुनिए : 1
  - (A) लिटमस और मेथिल ऑरैन्ज
  - (B) हल्दी और लिटमस
  - (C) फीनॉलफ्थेलिन और मेथिल ऑरैन्ज
  - (D) मेथिल ऑरैन्ज और हल्दी

## SECTION – A

(20 × 1 = 20)

In this section, Question Nos. 1 to 20 are Multiple-Choice Questions.

All questions are compulsory.

1. A chemical compound used in glass, soap and paper industries is 1

- (A) Washing Soda                      (B) Baking Soda  
(C) Bleaching Powder                (D) Common Salt

2. Which one of the following reactions is different from the remaining three ? 1

- (A)  $\text{NaCl} + \text{AgNO}_3 \rightarrow \text{AgCl} + \text{NaNO}_3$   
(B)  $\text{CaO} + \text{H}_2\text{O} \rightarrow \text{Ca(OH)}_2$   
(C)  $\text{KNO}_3 + \text{H}_2\text{SO}_4 \rightarrow \text{KHSO}_4 + \text{HNO}_3$   
(D)  $\text{ZnCl}_2 + \text{H}_2\text{S} \rightarrow \text{ZnS} + 2\text{HCl}$

3. Identify the product 'X' obtained in the following chemical reaction : 1

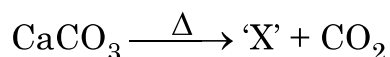

- (A) Quick lime                      (B) Gypsum  
(C) Lime Stone                      (D) Plaster of Paris

4. Select a pair of natural indicator from the following : 1

- (A) Litmus and methyl orange  
(B) Turmeric and Litmus  
(C) Phenolphthalein and methyl orange  
(D) Methyl orange and Turmeric

2231/3/2

5

P.T.O.



5. नीचे दिया गया कौन सा एक हाइड्रोकार्बन अन्य से भिन्न है ? 1

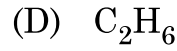
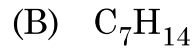
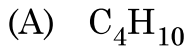

6. निम्नलिखित में से साबुनीकरण अभिक्रिया चुनिए : 1

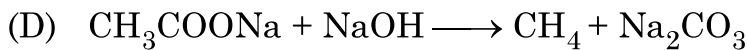
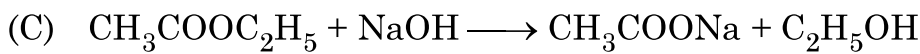
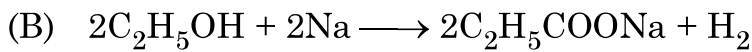

7. नीचे दिए गए रासायनिक समीकरण पर विचार कीजिए : 1

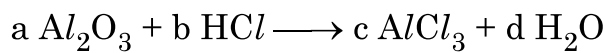

इस रासायनिक समीकरण को संतुलित बनाने के लिए a, b, c और d के मान क्रमशः होने चाहिए -

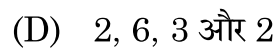
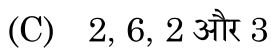
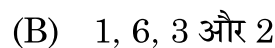
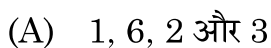

5. Which one of the following hydrocarbons is different from the others ? 1

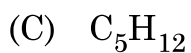

6. Select saponification reaction from the following : 1

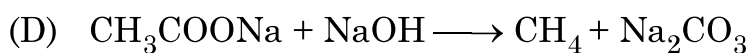
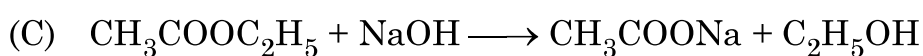
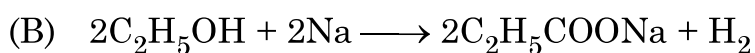

7. Consider the following chemical equation : 1

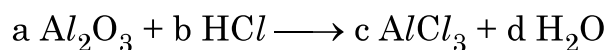

In order to balance this Chemical equation, the values of a, b, c and d must be

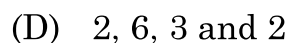
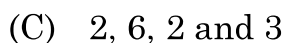
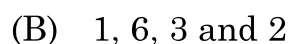
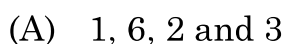

8. समान पदार्थ के चार तारों के प्रकरण में उस तार का प्रतिरोध निम्नतम होगा जिसका व्यास और लम्बाई क्रमशः हैं 1
- (A)  $D/2$  और  $L/4$  (B)  $D/4$  और  $4L$
- (C)  $2D$  और  $L$  (D)  $4D$  और  $2L$
9. संयुक्त राष्ट्र पर्यावरण कार्यक्रम द्वारा यह सर्वानुमति बनी कि 1
- (A) पर्यावरण में  $CO_2$  उत्सर्जन को नियंत्रित करना है।
- (B) जैव-विविधता का संरक्षण करना है।
- (C) जल प्रदूषण को नियंत्रित करना है।
- (D) CFC के उत्पादन को घटाना है।
10. नीचे दिया गया कौन सा कथन हाइड्रा, अमीबा और स्पाइरोगायरा के लिए सही है ? 1
- (A) ये बहुकोशिकीय जीव हैं। (B) ये एककोशिकीय जीव हैं।
- (C) ये लैंगिक जनन करते हैं। (D) ये अलैंगिक जनन करते हैं।
11. दो लम्बे मटर के पौधों के बीच संकरण के फलस्वरूप उत्पन्न संतति के पौधों में कुछ बौने पौधे प्राप्त हुए। जनक पौधों का जीन-संयोजन होना चाहिए - 1
- (A)  $Tt$  और  $Tt$  (B)  $Tt$  और  $tt$
- (C)  $TT$  और  $tt$  (D)  $TT$  और  $Tt$





8. In case of four wires of same material, the resistance will be minimum if the diameter and length of the wire respectively are 1
- (A)  $D/2$  and  $L/4$                       (B)  $D/4$  and  $4L$   
(C)  $2D$  and  $L$                       (D)  $4D$  and  $2L$
9. United Nations Environment Programme forged an agreement to 1
- (A) control  $CO_2$  emissions in the environment  
(B) conserve biodiversity  
(C) control water pollution  
(D) reduce CFC production
10. Which one of the following statements is TRUE for Hydra, Amoeba and Spirogyra ? 1
- (A) They are multicellular.              (B) They are unicellular.  
(C) They reproduce sexually.              (D) They reproduce asexually.
11. A cross between two tall pea plants resulted in offsprings having a few dwarf plants. The gene-combination of the parental plants must be 1
- (A)  $Tt$  and  $Tt$                       (B)  $Tt$  and  $tt$   
(C)  $TT$  and  $tt$                       (D)  $TT$  and  $Tt$



12. मानव हृदय के बारे नीचे दिए गए कथनों में सही कथन/कथनों को चुनिए : 1

- (a) दायाँ अलिन्द फुफ्फुस से फुफ्फुसीय धमनी द्वारा ऑक्सीजनित रुधिर प्राप्त करता है ।
- (b) बायाँ अलिन्द बाएँ निलय को ऑक्सीजनित रुधिर स्थानान्तरित करता है जो उसे शरीर के विभिन्न भागों तक पहुँचा देता है ।
- (c) दायाँ अलिन्द महाशिरा द्वारा शरीर के विभिन्न भागों से आने वाले विऑक्सीजनित रुधिर को प्राप्त करता है ।
- (d) बायाँ अलिन्द महाधमनी को ऑक्सीजनित रुधिर स्थानान्तरित करता है जो उसे शरीर के विभिन्न भागों को देती है ।

- (A) केवल (b) (B) (a) और (d)  
(C) (b) और (c) (D) (b) और (d)

13. परागण के लिए कीटों को आकर्षित करने वाला/वाले पुष्प का/के भाग है/हैं - 1

- (A) दल (पंखुड़ी) और बाह्य दल (B) परागकोश और वर्तिकाग्र  
(C) केवल दल (पंखुड़ी) (D) केवल बाह्य दल

14. आकाश में इन्द्रधनुष बनने में सम्मिलित होने वाली प्रकाश की परिघटनाएँ हैं 1

- (A) अपवर्तन, परिक्षेपण (विक्षेपण) और परावर्तन  
(B) अपवर्तन, परिक्षेपण (विक्षेपण) और पूर्ण आन्तरिक परावर्तन  
(C) परिक्षेपण (विक्षेपण), प्रकीर्णन और परावर्तन  
(D) परिक्षेपण (विक्षेपण), अपवर्तन और आन्तरिक परावर्तन

12. Which of the following statement (s) is (are) true about human heart ? 1

- (a) Right atrium receives oxygenated blood from lungs through pulmonary artery.
- (b) Left atrium transfers oxygenated blood to left ventricle which sends it to various parts of the body.
- (c) Right atrium receives deoxygenated blood from different parts of the body through vena cava.
- (d) Left atrium transfers oxygenated blood to aorta which sends it to different parts of the body.

- (A) (b) only (B) (a) and (d)
- (C) (b) and (c) (D) (b) and (d)

13. Part(s) of a flower which attracts insects for pollination is (are) 1

- (A) petals and Sepals (B) anther and Stigma
- (C) petals only (D) sepals only

14. The Phenomena of light involved in the formation of a rainbow in the sky are 1

- (A) Refraction, dispersion and reflection
- (B) Refraction, dispersion and total internal reflection
- (C) Dispersion, scattering and reflection
- (D) Dispersion, refraction and internal reflection

15. ओज़ोन के विषय में नीचे दिए गए कथनों पर विचार कीजिए :

1

- (a) ओज़ोन विषैली गैस है ।
- (b) ओज़ोन पृथ्वी के पृष्ठ को सूर्य से आने वाले हानिकर अवरक्त विकिरणों से सुरक्षा प्रदान करती है ।
- (c) पराबैंगनी विकिरणों के प्रभाव से ऑक्सीजन ( $O_2$ ) अणुओं से ओज़ोन बनती है ।
- (d) पृथ्वी के वायुमंडल के निचले स्तर पर ओज़ोन एक अत्यन्त आवश्यक प्रकार्य सम्पादित करती है ।

इनमें सही कथन हैं -

- (A) (a) और (b)
- (B) (a) और (c)
- (C) (b) और (c)
- (D) (b) और (d)

16. ऊर्जा के पदों में कोई आहार शृंखला तब अधिक लाभकारी होती है, जब उसमें होते हैं

1

- (A) दो पोषी स्तर
- (B) तीन पोषी स्तर
- (C) चार पोषी स्तर
- (D) पाँच पोषी स्तर

प्रश्न संख्या 17 से 20 इन प्रश्नों में दो कथन – अभिकथन (A) और कारण (R) दिए गए हैं । इन प्रश्नों के उत्तर नीचे दिए अनुसार उचित विकल्प को चुनकर दीजिए :

- (A) (A) और (R) दोनों सही हैं तथा (R) द्वारा (A) की सही व्याख्या हो रही है ।
- (B) (A) और (R) दोनों सही हैं तथा (R) द्वारा (A) की सही व्याख्या नहीं हो रही है ।
- (C) (A) सही है, परन्तु (R) गलत है ।
- (D) (A) गलत है, परन्तु (R) सही है ।

17. अभिकथन (A) : धातुओं के ऑक्साइड क्षारकीय लक्षण दर्शाते हैं ।

1

कारण (R) : धातुओं के ऑक्साइड अम्ल से अभिक्रिया करके लवण और जल बनाते हैं ।

15. Consider the following statements about ozone :

1

- (a) Ozone is poisonous gas.
- (b) Ozone shields the earth's surface from the infrared radiation from the sun.
- (c) Ozone is a product of UV radiations acting on oxygen molecule.
- (d) At the lower level of the earth's atmosphere, ozone performs most essential function.

The correct statements are

- (A) (a) and (b)
- (B) (a) and (c)
- (C) (b) and (c)
- (D) (b) and (d)

16. A food chain will be more advantageous in terms of energy if it has

1

- (A) 2 trophic levels
- (B) 3 trophic levels
- (C) 4 trophic levels
- (D) 5 trophic levels

**Q. 17 to 20** consists of two statements – Assertion (A) and Reason (R), answer these questions selecting the appropriate option given below :

- (A) Both (A) and (R) are true and (R) is the correct explanation of (A).
- (B) Both (A) and (R) are true and (R) is not correct explanation of (A).
- (C) (A) is true, but (R) is false.
- (D) (A) is false, but (R) is true.

17. **Assertion (A)** : Oxides of metals show basic characters.

1

**Reason (R)** : Oxides of metals react with acid to form salt and water.



18. **अभिकथन (A)** : सड़क पर वाहनों को रोकने के लिए लाल प्रकाश के सिग्नलों का उपयोग किया जाता है। 1
- कारण (R)** : सबसे अधिक प्रकीर्णित होने के कारण लाल प्रकाश को अधिक दूरी से देखा जा सकता है।
19. **अभिकथन (A)** : मानव नरों में 'XX' लिंग गुणसूत्र तथा मादाओं में 'XY' लिंग गुणसूत्र होते हैं। 1
- कारण (R)** : किसी शिशु का लिंग निर्धारण निषेचन के समय होता है, जब नर और मादा युग्मक संलयन द्वारा युग्मनज बनाते हैं।
20. **अभिकथन (A)** : ग्राही प्रायः हमारी ज्ञानेन्द्रियों में स्थित होते हैं तथा किसी विशेष उद्दीपन का अनुभव करते हैं। 1
- कारण (R)** : उद्दीपनों के संसूचन के लिए विभिन्न ज्ञानेन्द्रियों में विभिन्न ग्राही होते हैं।

### खण्ड – ख

प्रश्न संख्या 21 से 26 अति लघु उत्तर प्रश्न हैं। प्रत्येक प्रश्न 2 अंकों का है।

21. जब सोडियम सल्फेट के जलीय विलयन में बेरियम क्लोराइड की कुछ बूँदें मिलायी जाती हैं, तो कोई श्वेत अवक्षेप बनता है। 2
- (a) होने वाली अभिक्रिया का संतुलित रासायनिक समीकरण लिखिए।
- (b) इस अवक्षेपण अभिक्रिया का दूसरा नाम क्या है ? इसे यह नाम क्यों दिया गया है ?
22. यह हम कब कहते हैं कि कोई व्यक्ति दीर्घ-दृष्टि दोष (दूर-दृष्टिता) से पीड़ित है ? इस दोष के दो कारणों की सूची बनाइए। इस दोष के संशोधन के लिए उपयोग किए जाने लेंस के प्रकार का नाम लिखिए। 2



18. **Assertion (A)** : Red light signals are used to stop the vehicles on the road. **1**

**Reason (R)** : Red coloured light is scattered the most so as to be visible from a large distance.

19. **Assertion (A)** : In human beings, males have 'XX' sex chromosomes and females have 'XY' sex chromosomes. **1**

**Reason (R)** : Sex of the child is determined at the time of fertilisation when male and female gamete fuse to form a zygote.

20. **Assertion (A)** : Receptors are usually located in our sense organs and perceive a particular stimulus. **1**

**Reason (R)** : Different sense organs have different receptors for detecting stimuli.

### SECTION – B

**Question Nos. 21 to 26 are very short answer type questions. Each question carries 2 marks.**

21. When a few drops of Barium chloride solution are added to an aqueous solution of Sodium sulphate, a white precipitate is obtained. **2**

(a) Write balanced chemical equation for the reaction involved.

(b) What is the other name of this precipitation reaction ? Why is it called so ?

22. When do we say that a particular person is suffering from hypermetropia ? List two causes of this defect. Name the type of lens used to correct this defect. **2**

23. (a) किसी सीधे धारावाही चालक के कारण उत्पन्न चुम्बकीय क्षेत्र रेखाओं के पैटर्न को दर्शाने के लिए नामांकित आरेख खींचिए। इस आरेख में चालक में प्रवाहित धारा की दिशा और चुम्बकीय क्षेत्र रेखाओं की दिशा अंकित कीजिए।

2

अथवा

23. (b) उस युक्ति का नाम लिखिए जिसका उपयोग किसी चुम्बकीय पदार्थ के टुकड़े को चुम्बकित करने में किया जाता है। उस व्यवस्था को दर्शाने के लिए नामांकित आरेख खींचिए जिसका उपयोग नर्म लोहे के सिलिण्डर को चुम्बकित करने में किया जाता है।

2

24. ऑक्सिन का संश्लेषण कहाँ होता है ? ये प्रकाशानुवर्तन को किस प्रकार बढ़ावा देते हैं ?

2

25. (a) मटर के पौधों के किन्हीं दो दृष्टिगोचर होने वाले विपर्यासी लक्षणों के युगलों (जोड़ों) की सूची बनाइए जिनका उपयोग मेंडल ने अपने प्रयोगों में किया था। प्रत्येक जोड़े के प्रभावी और अप्रभावी लक्षणों का उल्लेख भी कीजिए।

2

अथवा

25. (b) मानवों में शिशु नर होगा अथवा मादा होगा इसकी प्रायिकता (संभावना) 50% होती है। केवल प्रवाह आरेख खींचकर इस कथन की व्याख्या कीजिए।

2

26. जैव-निम्नीकरणीय और अजैव-निम्नीकरणीय पदार्थों की परिभाषा दीजिए। निम्नलिखित मदों को इन दो वर्गों में वर्गीकृत कीजिए :

2

समाचार-पत्र (अखबार), काँच की बोतलें, पॉलीथीन की थैलियाँ, सब्जियों के छिलके





23. (a) Draw a labelled diagram to show the pattern of magnetic field lines produced due to a current carrying straight conductor. Mark on it the direction of current in the conductor and the direction of magnetic field lines. 2

**OR**

23. (b) Name the device used to magnetise a piece of magnetic material. Draw a labelled diagram to show the arrangement used for the magnetisation of a cylinder made of soft iron. 2

24. Where are auxins synthesized ? How do they promote phototropism ? 2

25. (a) List any two pairs of visible contrasting characters of garden pea plants used by Mendel for his experiments stating the dominant and recessive characters in each pair. 2

**OR**

25. (b) In human beings, the probability of getting a male or a female child is 50%. Explain with the help of a flow diagram only. 2

26. Define the terms biodegradable and non-biodegradable substance. Classify the following items into these two categories : 2

Newspapers, Glass bottles, Polythene bags, Vegetable peels



### खण्ड – ग

प्रश्न संख्या 27 से 33 लघु उत्तर प्रश्न हैं। प्रत्येक प्रश्न 3 अंकों का है।

27. (a) नीचे दी गयी धातुओं को उनके यौगिकों से प्राप्त करने के लिए उपयोग की जाने वाली अपचयन प्रक्रिया का कारण सहित उल्लेख कीजिए :

3

(i) मरकरी,

(ii) कॉपर तथा

(iii) सोडियम

### अथवा

27. (b) नीचे दी गयी प्रत्येक धातु को कुछ समय तक वायुमंडलीय वायु में खुला रखने पर उसकी दिखावट में होने वाले परिवर्तनों का, कारण देते हुए, उल्लेख कीजिए :

3

(i) सिल्वर,

(ii) कॉपर तथा

(iii) आयरन

28. सोडियम (परमाणु संख्या 11) और ऑक्सीजन (परमाणु संख्या 8) का इलेक्ट्रॉनिक विन्यास लिखिए और इन दोनों तत्वों के मिलने से प्राप्त आयनी यौगिक का बनना दर्शाइए। इस यौगिक में उपस्थित धनायन और ऋणायन के नाम लिखिए।

3

29. (a) केन्द्रीय तंत्रिका तंत्र (CNS) के दो संघटकों की सूची बनाइए। इन संघटकों की चोटों से सुरक्षा किस प्रकार होती है ?

(b) विद्युत आवेगों के उपयोग की दो सीमाओं का उल्लेख कीजिए।

3

## SECTION – C

**Question Nos. 27 to 33 are short answer type questions. Each question carries 3 marks.**

27. (a) State giving reason the reduction process to obtain the following metals from their compounds : 3
- (i) Mercury,
  - (ii) Copper and
  - (iii) Sodium

**OR**

27. (b) State giving reason for the change in appearance observed when each of the following metal is exposed to atmospheric air for some time : 3
- (i) Silver,
  - (ii) Copper and
  - (iii) Iron

28. Write electronic configuration of Sodium (At. No.11) and Oxygen (At. No. 8) and show the formation of the ionic compound obtained when these two elements combine. Name anion and cation present in the compound. 3

29. (a) List two constituents of Central Nervous System (CNS). How are these components protected from injuries ?
- (b) Write two limitations of the use of electrical impulses. 3

30. वायवीय श्वसन और अवायवीय श्वसन के बीच मुख्य अन्तर लिखिए । दोनों के उभयनिष्ठ पथ का उल्लेख कीजिए । वायवीय श्वसन का समग्र (व्यापक) रासायनिक समीकरण लिखिए । कोशिकाओं के भीतर के उस स्थल का उल्लेख कीजिए जहाँ यह प्रक्रिया होती है । 3
31. घरेलू परिपथों में विद्युत फ्यूज के कार्य की संक्षेप में व्याख्या कीजिए । 3 kW; 220 V अनुमतांक के किसी विद्युत हीटर को 5 A धारा अनुमतांक के विद्युत परिपथ में प्रचालित किया जाना है । विद्युत हीटर के स्विच को 'ऑन' करने पर क्या हो सकता है ? आवश्यक परिकल्पनों की सहायता से अपने उत्तर की पुष्टि कीजिए । 3
32. प्रकाश की उस परिघटना का नाम लिखिए तथा उसकी व्याख्या कीजिए जिसके कारण किसी सूक्ष्म छिद्र से धुँएँ से भरे किसी कमरे में आने वाले प्रकाश पुन्ज का मार्ग दिखाई देने लगता है । यह भी उल्लेख कीजिए कि हमारे नेत्रों तक आने वाले प्रकाश का रंग जिस माध्यम से होकर प्रकाश पुन्ज गुजरता है, उस माध्यम के कणों के साइज़ पर किस प्रकार निर्भर करता है । 3
33. घरेलू तारों को बिछाने में पार्श्व परिपथों के तीन लाभों की सूची बनाइए । 3

### खण्ड – घ

प्रश्न संख्या 34 से 36 दीर्घ उत्तर प्रश्न हैं । प्रत्येक प्रश्न 5 अंकों का है ।

34. (a) (i) नीचे दिए गए प्रत्येक प्रकरण में अपवर्तित किरण का पथ दर्शाने के लिए किरण आरेख खींचिए :
- किसी अवतल लेंस पर आपतित उस प्रकाश किरण का
- (1) जो मुख्य अक्ष के समान्तर गतिमान है, तथा
  - (2) जो मुख्य फोकस की ओर दिशिक (जाती दिखाई देती) है ।

30. Write the main difference between aerobic and anaerobic respiration. State the pathway which is common for both. Write the overall chemical equation of aerobic respiration and mention the site where this process occurs inside the cells. 3
31. Explain in brief the function of an electric fuse in a domestic circuit. An electric heater of current rating 3 kW; 220 V is to be operated in an electric circuit of rating 5 A. What is likely to happen when the heater is switched 'ON' ? Justify your answer with necessary calculation. 3
32. Name and explain the phenomenon of light due to which the path of a beam of light becomes visible when it enters a smoke filled room through a small hole. Also state the dependence of colour of the light we receive on the size of the particle of the medium through which the beam of light passes. 3
33. List three advantages of parallel circuits in domestic wiring. 3

### SECTION – D

**Question Nos. 34 to 36 are long answer type questions. Each question carries 5 marks.**

34. (a) (i) Draw a ray diagram to show the path of the refracted ray in each of the following cases :
- A ray of light incident on a concave lens
- (1) parallel to its principal axis, and
  - (2) is directed towards its principal focus.

- (ii) 4 cm ऊँचा कोई बिम्ब 24 cm फोकस दूरी के किसी उत्तल लेंस के मुख्य अक्ष पर लम्बवत स्थित है। लेंस से बिम्ब की दूरी 16 cm है। प्रतिबिम्ब की स्थिति और साइज़ ज्ञात कीजिए।

5

### अथवा

34. (b) (i) नीचे दिए गए प्रत्येक प्रकरण में परावर्तित किरण का पथ दर्शाने के लिए किरण आरेख खींचिए :

किसी उत्तल दर्पण पर आपतित उस प्रकाश किरण का

- (1) जो मुख्य अक्ष के समान्तर गतिमान है, तथा
- (2) जो मुख्य फोकस की ओर दिशिक (जाती दिखाई देती) है।

- (ii) 1.5 cm ऊँची मोमबत्ती की ज्वाला 12 cm फोकस दूरी के किसी अवतल दर्पण के मुख्य अक्ष पर लम्बवत रखी है। यदि ज्वाला की दर्पण के ध्रुव से दूरी 18 cm है, तो दर्पण सूत्र का उपयोग करके प्रतिबिम्ब की स्थिति और उसका साइज़ निर्धारित कीजिए।

5

35. (a) यौवनारम्भ किसे कहते हैं ? प्रारम्भिक किशोरावस्था में लड़कों में होने वाले किन्हीं दो परिवर्तनों का उल्लेख कीजिए।

- (b) मानव नरों में वृषणों के दो कार्यों की सूची बनाइए। मानव नर जनन तंत्र में निम्नलिखित में प्रत्येक की एक भूमिका का उल्लेख कीजिए :

- (i) शुक्रवाहिनी, (ii) शुक्राशय (iii) मूत्रमार्ग तथा (iv) वृषण कोश

5

### अथवा

- (a) मानव मादा जनन तंत्र के नीचे दिए गए प्रत्येक भाग के दो कार्य लिखिए :

- (i) अण्डाशय
- (ii) अण्डवाहिका
- (iii) गर्भाशय

- (b) प्लैसेन्टा की संरचना और कार्य का वर्णन कीजिए।

5



- (ii) A 4 cm tall object is placed perpendicular to the principal axis of convex lens of focal length 24 cm. The distance of object from the lens is 16 cm. Find the position and size of image formed. **5**

**OR**

34. (b) (i) Draw a ray diagram to show the path of the reflected ray in each of the following cases :

A ray of light incident on a convex mirror

- (1) parallel to its principal axis, and
- (2) is directed towards its principal focus

- (ii) A 1.5 cm tall candle flame is placed perpendicular to the principal axis of a concave mirror of focal length 12 cm. If the distance of the flame from the pole of the mirror is 18 cm, use mirror formula to determine the position and size of the image formed. **5**

35. (a) What is puberty ? Write any two changes that occur in boys during early teenage years.

- (b) List two functions performed by testis in human males.

Mention one role each of (i) Vas deferens, (ii) Seminal Vesicle (iii) Urethra and (iv) Scrotum in human male reproductive system. **5**

**OR**

- (a) Write two functions each of the following parts in human female reproductive system :

- (i) Ovary
- (ii) Oviduct
- (iii) Uterus

- (b) Describe the structure and function of placenta. **5**

36. (a) (i) pH पेपर के साथ परीक्षण करने पर पाँच विलयनों A, B, C, D और E के pH क्रमशः 4, 1, 13, 7 और 10 दर्शाए गए। इनमें से कौन सा विलयन -

(1) प्रबल अम्लीय, (2) प्रबल क्षारकीय, (3) दुर्बल अम्लीय, (4) उदासीन तथा (5) दुर्बल क्षारकीय है ? इन विलयनों को इनकी बढ़ती  $H^+$  आयन सांद्रता के क्रम में व्यवस्थित कीजिए।

(ii) (1) एक अम्लीय लवण और (2) एक क्षारकीय लवण का नाम लिखिए और प्रत्येक प्रकरण में इन लवणों के जनक अम्ल और जनक क्षारक का नाम भी दीजिए।

5

### अथवा

36. (b) सोडियम क्लोराइड से सोडियम हाइड्रॉक्साइड बनाने की प्रक्रिया का नाम लिखिए और उसका संक्षेप में उल्लेख कीजिए। इस प्रक्रिया में मुख्य उत्पाद के साथ दो गैसों 'X' और 'Y' भी दो इलेक्ट्रोडों पर निकलती हैं। 'X' और 'Y' के नाम तथा जिन इलेक्ट्रोडों पर ये प्राप्त होती हैं उनके नाम भी क्रमशः लिखिए। इन दोनों गैसों में एक गैस जब शुष्क कैल्सियम हाइड्रॉक्साइड से अभिक्रिया करती है, तो कोई यौगिक 'Z' बनता है जिसका उपयोग पीने के पानी को जीवाणु से मुक्त कराने वाले संयंत्रों में तथा वस्त्र उद्योग में होता है। Z का नाम तथा इसके बनने में होने वाली रासायनिक अभिक्रिया का रासायनिक समीकरण लिखिए।

5





36. (a) (i) Five solutions A, B, C, D and E when tested with pH paper showed pH as 4, 1, 13, 7 and 10 respectively. Which solution is :

(1) Strongly acidic (2) Strongly alkaline (3) Weakly acidic  
(4) Neutral and (5) Weakly alkaline ? Arrange the solutions in increasing order of  $H^+$  ion concentration.

(ii) Write the name and formula of (1) an acidic salt and (2) a basic salt giving the name of the parent acid and parent base used to form the salt in each case.

5

OR

36. (b) Name and state in brief the process which is used to prepare sodium hydroxide from sodium chloride. In this process along with the main product two gases 'X' and 'Y' are also given off at the two electrodes. Name 'X' and 'Y' specifying the name of their respective electrode at which each gas is obtained. One of these gases when reacts with dry calcium hydroxide produces a compound 'Z' which is widely used in water treatment plants and textile industries. Name Z and write chemical equation for the reaction involved in its formation.

5



### खण्ड – ड

प्रश्न संख्या 37 से 39 स्रोत आधारित/प्रकरण आधारित प्रश्न हैं। प्रत्येक प्रश्न 4 अंकों का है।

37. रसायन के क्षेत्र में तीस लाख से भी अधिक कार्बन के यौगिकों की खोज हो चुकी है। इन यौगिकों की विभिन्नता का कारण कार्बन परमाणुओं की परस्पर आबन्ध बनाने और अन्य तत्वों के साथ आबन्ध बनाने की क्षमता होना है। कार्बन के अधिकांश यौगिक विद्युत के कुचालक होते हैं तथा इनके गलनांक और क्वथनांक निम्न होते हैं।

4

(a) उस समजातीय श्रेणी के पहले दो सदस्यों का आण्विक सूत्र लिखिए जिनका प्रकार्यात्मक समूह  $-\text{Br}$  है।

1

(b) नीचे कुछ प्रकार्यात्मक समूहों के सूत्र दिए गए हैं :

1



इन प्रकार्यात्मक समूहों का नाम लिखिए।

(c) आप क्या प्रेक्षण करते हैं जब आप किसी परखनली में कुछ गरम एथेनॉल लेकर उसमें बूँद-बूँद करके 5% क्षारीय पोटैशियम परमैंगनेट मिलाते हैं ? इसमें पोटैशियम परमैंगनेट की भूमिका का उल्लेख कीजिए तथा होने वाली अभिक्रिया का रासायनिक समीकरण लिखिए।

2

### अथवा

(c) एथेनॉल को आधिक्य सांद्र सल्फ्युरिक अम्ल के साथ 443 K ताप पर गरम करने पर बनने वाले यौगिक का नाम लिखिए। इस अभिक्रिया में सांद्र सल्फ्युरिक अम्ल की भूमिका का उल्लेख कीजिए तथा होने वाली अभिक्रिया का रासायनिक समीकरण लिखिए।

2



## SECTION – E

Question Nos. 37 to 39 are Case/Source based questions. Each question carries 4 marks.

37. More than three million carbon compounds have been discovered in the field of chemistry. The diversity of these compounds is due to the capacity of carbon atoms for bonding with one another as well as with other atoms. Most of the carbon compounds are poor conductors of electricity and have low melting and boiling points. 4

(a) Write the molecular formula of first two members of homologous series having functional group –Br. 1

(b) Given below are the formulae of some functional groups : 1

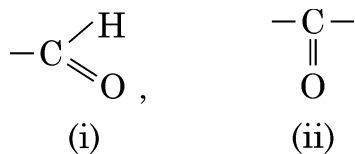

Write the name of these functional groups.

(c) What would be observed on adding a 5% alkaline potassium permanganate drop by drop to some warm ethanol taken in a test tube ? State the role of  $\text{KMnO}_4$  in the reaction and write the chemical equation for the reaction involved. 2

OR

(c) Write the name of the compound formed when ethanol is heated at 443 K temperature with excess of conc.  $\text{H}_2\text{SO}_4$ . What is the role of conc.  $\text{H}_2\text{SO}_4$  in the reaction ? Write the chemical equation for the reaction involved. 2



38. मानव पाचन तंत्र एक नलिका होती है जो मुँह से गुहा तक जाती है। इसका मुख्य कार्य भोजन में उपस्थित जटिल अणुओं, जो उसी रूप में अवशोषित नहीं हो सकते हैं, को छोटे अणुओं में खंडित करना होता है। ये छोटे अणु इस नलिका की भित्तियों में अवशोषित होते हैं तथा अवशोषित भोजन शरीर की प्रत्येक कोशिका तक पहुँचता है जहाँ इसका उपयोग ऊर्जा प्राप्त करने के लिए किया जाता है।

4

(a) मुख गुहा में उपस्थित ग्रंथियों का नाम लिखिए तथा भोजन के उस घटक का उल्लेख कीजिए जिस पर इन ग्रंथियों के स्राव क्रिया करते हैं।

1

(b) दो अंगों में निकास पर अवरोधिनी पेशी होती है। इनका नाम लिखिए।

1

(c) क्या होगा यदि

(i) जठर ग्रंथियों द्वारा श्लेष्मा का स्रावण नहीं किया जाए ?

(ii) क्षुद्रांत्र में दीर्घ रोम उपस्थित न हों ?

2

अथवा

(c) “पित्त रस में कोई एन्जाइम नहीं होते, फिर भी यह पाचन में एक महत्वपूर्ण भूमिका निभाता है।” इस कथन की पुष्टि कीजिए।

2

39. किसी घरेलू परिपथ में पाँच LED बल्ब आरेख में दर्शाए अनुसार व्यवस्थित हैं। स्रोत की वाटता 220V है तथा प्रत्येक बल्ब का शक्ति अनुमतांक परिपथ आरेख में बल्ब के साथ अंकित किया गया है। नीचे दिए गए परिपथ आरेख के आधार पर निम्नलिखित प्रश्नों के उत्तर दीजिए :

4

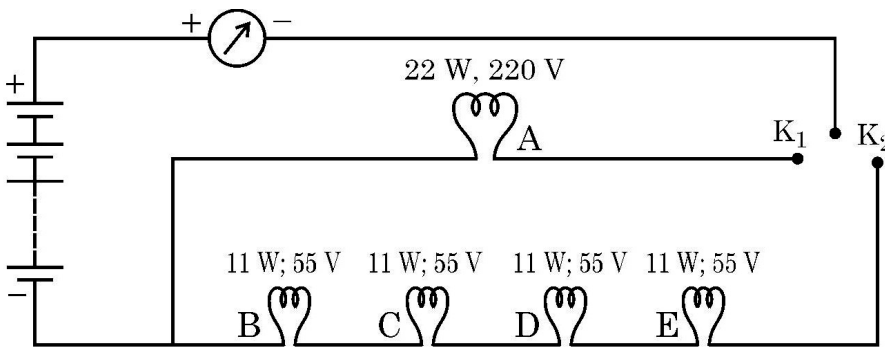

(a) उल्लेख कीजिए क्या होता है जब

1

(i) कुंजी  $K_1$  को बन्द करते हैं।

(ii) कुंजी  $K_2$  को बन्द करते हैं।

38. Human digestive system is a tube running from mouth to anus. Its main function is to breakdown complex molecules present in the food which cannot be absorbed as such into smaller molecules. These molecules are absorbed across the walls of the tube and the absorbed food reaches each and every cell of the body where it is utilised for obtaining energy. 4

(a) Name the glands present in the buccal cavity and write the components of food on which the secretion of these glands act upon. 1

(b) Two organs have a sphincter muscle at their exit. Name them. 1

(c) What will happen if :

(i) mucus is not secreted by the gastric glands.

(ii) Villi are absent in the small intestine. 2

**OR**

(c) "Bile juice does not contain any enzyme, yet it has important roles in digestion." Justify the statement. 2

39. In a domestic circuit five LED bulbs are arranged as shown. The source voltage is 220 V and the power rating of each bulb is marked in the circuit diagram. Based on the following circuit diagram, answer the following questions : 4

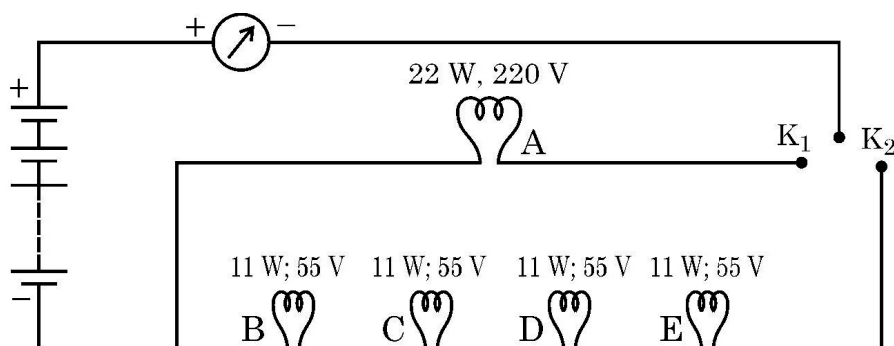

(a) State what happens when 1

(i) key K<sub>1</sub> is closed.

(ii) key K<sub>2</sub> is closed.

(b) जब बल्ब B चमक रहा होता है तब वह कितनी धारा लेता है ? 1

(c) परिकल्पित कीजिए : 2

(i) बल्ब B का प्रतिरोध, तथा

(ii) चारों बल्ब B, C, D और E के संयोजन का कुल प्रतिरोध

अथवा

(c) परिपथ के सभी बल्बों की चमक का क्या होगा जबकि कुंजी  $K_1$  तथा  $K_2$  दोनों बन्द हैं तथा अचानक बल्ब C फ्यूज़ हो जाता है ? अपने उत्तर की पुष्टि के लिए कारण दीजिए । 2

(b) Find the current drawn by the bulb B when it glows. **1**

(c) Calculate **2**

(i) the resistance of bulb B, and

(ii) total resistance of the combination of four bulbs B, C, D and E.

**OR**

(c) What would happen to the glow of all the bulbs in the circuit when keys  $K_1$  and  $K_2$  both are closed and the bulb C suddenly get fused ?

Give reason to justify your answer. **2**

---

2231/3/2

**112 B**

32



**Marking Scheme**  
**Strictly Confidential**  
**(For Internal and Restricted use only)**  
**Secondary School Examination, 2024**  
**SUBJECT NAME SCIENCE (086) (Q.P. CODE 31/3/1)**

**General Instructions: -**

1	You are aware that evaluation is the most important process in the actual and correct assessment of the candidates. A small mistake in evaluation may lead to serious problems which may affect the future of the candidates, education system and teaching profession. To avoid mistakes, it is requested that before starting evaluation, you must read and understand the spot evaluation guidelines carefully.
2	“Evaluation policy is a confidential policy as it is related to the confidentiality of the examinations conducted, Evaluation done and several other aspects. Its’ leakage to public in any manner could lead to derailment of the examination system and affect the life and future of millions of candidates. Sharing this policy/document to anyone, publishing in any magazine and printing in News Paper/Website etc may invite action under various rules of the Board and IPC.”
3	Evaluation is to be done as per instructions provided in the Marking Scheme. It should not be done according to one’s own interpretation or any other consideration. Marking Scheme should be strictly adhered to and religiously followed. However, while evaluating, answers which are based on latest information or knowledge and/or are innovative, they may be assessed for their correctness otherwise and due marks be awarded to them. In class-X, while evaluating two competency-based questions, please try to understand given answer and even if reply is not from marking scheme but correct competency is enumerated by the candidate, due marks should be awarded.
4	The Marking scheme carries only suggested value points for the answers These are in the nature of Guidelines only and do not constitute the complete answer. The students can have their own expression and if the expression is correct, the due marks should be awarded accordingly.
5	The Head-Examiner must go through the first five answer books evaluated by each evaluator on the first day, to ensure that evaluation has been carried out as per the instructions given in the Marking Scheme. If there is any variation, the same should be zero after deliberation and discussion. The remaining answer books meant for evaluation shall be given only after ensuring that there is no significant variation in the marking of individual evaluators.
6	Evaluators will mark(√) wherever answer is correct. For wrong answer CROSS ‘X’ be marked. Evaluators will not put right (√)while evaluating which gives an impression that answer is correct and no marks are awarded. This is most common mistake which evaluators are committing.
7	If a question has parts, please award marks on the right-hand side for each part. Marks awarded for different parts of the question should then be totaled up and written in the left-hand margin and encircled. This may be followed strictly.
8	If a question does not have any parts, marks must be awarded in the left-hand margin and encircled. This may also be followed strictly.
9	If a student has attempted an extra question, answer of the question deserving more marks should be retained and the other answer scored out with a note “Extra Question”.

10	No marks to be deducted for the cumulative effect of an error. It should be penalized only once.
11	A full scale of marks __0-80_____(example 0 to 80/70/60/50/40/30 marks as given in Question Paper) has to be used. Please do not hesitate to award full marks if the answer deserves it.
12	Every examiner has to necessarily do evaluation work for full working hours i.e., 8 hours every day and evaluate 20 answer books per day in main subjects and 25 answer books per day in other subjects (Details are given in Spot Guidelines). This is in view of the reduced syllabus and number of questions in question paper.
13	Ensure that you do not make the following common types of errors committed by the Examiner in the past:- Leaving answer or part thereof unassessed in an answer book. Giving more marks for an answer than assigned to it. Wrong totaling of marks awarded on an answer. Wrong transfer of marks from the inside pages of the answer book to the title page. Wrong question wise totaling on the title page. Wrong totaling of marks of the two columns on the title page. Wrong grand total. Marks in words and figures not tallying/not same. Wrong transfer of marks from the answer book to online award list. Answers marked as correct, but marks not awarded. (Ensure that the right tick mark is correctly and clearly indicated. It should merely be a line. Same is with the X for incorrect answer.) Half or a part of answer marked correct and the rest as wrong, but no marks awarded.
14	While evaluating the answer books if the answer is found to be totally incorrect, it should be marked as cross (X) and awarded zero (0)Marks.
15	Any unassessed portion, non-carrying over of marks to the title page, or totaling error detected by the candidate shall damage the prestige of all the personnel engaged in the evaluation work as also of the Board. Hence, in order to uphold the prestige of all concerned, it is again reiterated that the instructions be followed meticulously and judiciously.
16	The Examiners should acquaint themselves with the guidelines given in the “Guidelines for Spot Evaluation” before starting the actual evaluation.
17	Every Examiner shall also ensure that all the answers are evaluated, marks carried over to the title page, correctly totaled and written in figures and words.
18	The candidates are entitled to obtain photocopy of the Answer Book on request on payment of the prescribed processing fee. All Examiners/Additional Head Examiners/Head Examiners are once again reminded that they must ensure that evaluation is carried out strictly as per value points for each answer as given in the Marking Scheme.



**MARKING SCHEME**  
**Secondary School Examination, 2024**  
**SCIENCE (Subject Code–086)**  
**[ Paper Code: 31/3/1]**

**Maximum Marks: 80**

Q. No.	EXPECTED ANSWER / VALUE POINTS	Marks	Total Marks
<b>SECTION A</b>			
1	(A) / Quick lime	1	1
2	(B) / Turmeric and litmus	1	1
3	(A) / Washing Soda	1	1
4	(B)	1	1
5	(A) / 1, 6, 2 and 3	1	1
6	(B) / C <sub>7</sub> H <sub>14</sub>	1	1
7	(B) / CaO + H <sub>2</sub> O → Ca(OH) <sub>2</sub>	1	1
8	(D) / Cytokinins	1	1
9	(C) / Petals only	1	1
10	(C) / 9 : 3 : 3 : 1	1	1
11	(C) / (b) and (c)	1	1
12	(A) / Tt and Tt	1	1
13	(D) / Dispersion, refraction and internal reflection	1	1
14	(D) / 4D and 2L	1	1
15	(A) / 2 trophic levels	1	1
16	(B) / (a) and (c)	1	1
17	(C) / Assertion (A) is true, but Reason (R) is false	1	1
18	(A) / Both Assertion (A) and Reason (R) are true, and Reason (R) is the correct explanation of Assertion (A)	1	1
19	(C) / Assertion (A) is true, but Reason (R) is false	1	1
20	(B) / Both Assertion (A) and Reason (R) are true, but Reason (R) is <i>not</i> the correct explanation of Assertion (A).	1	1
<b>SECTION B</b>			
21	<ul style="list-style-type: none"> <li>• 2 Mg + O<sub>2</sub> → 2 MgO</li> <li>• Magnesium oxide</li> <li>• Type – Combination reaction</li> <li>• Reason : Two or more substances combine to form a single product .</li> </ul>	½ ½ ½ ½	2
22	<ul style="list-style-type: none"> <li>• Synthesized at shoot tip/root tip</li> <li>• When light falls on one side of the plant, auxin diffuses towards the shady side of shoot. The concentration of auxin stimulates the cells to grow longer on the side of shoot which is away from light. Thus plant appears bent towards light/phototropism.</li> </ul>	½  1½	2

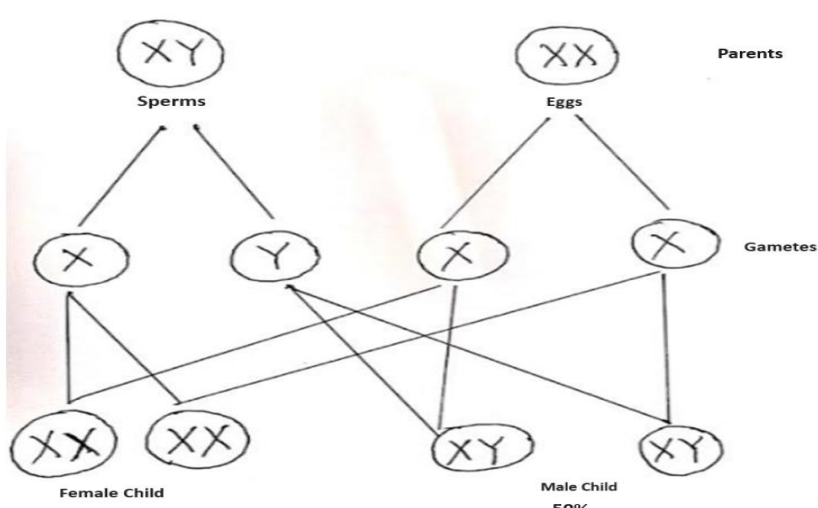
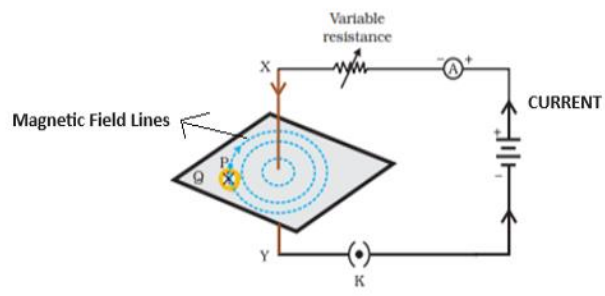
23	<p>(a) 2 visible characters of garden pea plants are :</p> <ul style="list-style-type: none"> <li>• Tallness (dominant) , Dwarfness (recessive)</li> <li>• Yellow seeds (dominant) , Green seeds (recessive)</li> </ul> <p style="text-align: right;">(Any other pair)</p> <p style="text-align: center;"><b>OR</b></p> <p>(b)</p> 	$\frac{1}{2} + \frac{1}{2}$ $\frac{1}{2} + \frac{1}{2}$ $\frac{1}{2}$ $\frac{1}{2}$ $\frac{1}{2}$ $\frac{1}{2}$	2
24	<ul style="list-style-type: none"> <li>• When he cannot see nearby objects distinctly but can see far object clearly.</li> <li>• 2 causes: Focal length of the eye lens is too long. Eyeball becomes too small.</li> <li>• Convex or Converging lens</li> </ul>	$\frac{1}{2}$ $\frac{1}{2}$ $\frac{1}{2}$ $\frac{1}{2}$	2
25	<p>(a)</p>  <p style="text-align: center;">Fig.12.6(a) on page 199-NCERT</p> <p style="text-align: right;"><b>Diagram: Directions of current and magnetic field:</b></p>	$\frac{1}{2} + \frac{1}{2}$	1

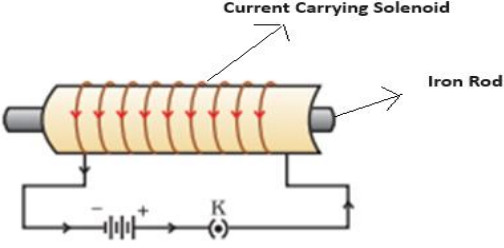
	<b>OR</b>		
	<p>(b)</p> <ul style="list-style-type: none"> <li>• Permanent magnet / Current carrying solenoid/ Electromagnet</li> <li>•</li> </ul> <div style="text-align: center;">  <p>Fig-12.11, page no.201-NCERT</p> </div>	1/2	
	<b>Diagram:</b>	1	2
	<b>Labelling:</b>	1/2	
26	<ul style="list-style-type: none"> <li>• Decomposers are the microorganisms that break-down the complex organic substances into simple inorganic substances.</li> </ul> <p><b>Consequences :</b></p> <ul style="list-style-type: none"> <li>(i) No replenishment of soil</li> <li>(ii) Foul smell</li> <li>(iii) Breeding of flies</li> <li>(iv) Accumulation of dead plants and animals in the environment.</li> <li>(v) No recycling of nutrients</li> </ul> <p style="text-align: right;"><b>(Any two or any other )</b></p>	1	
		1/2 + 1/2	2
	<b>SECTION C</b>		
27	<p>(a) Amphoteric oxide (zinc oxide) reacts with acids as well as bases to produce salt and water.</p> <p>(b) If kept in open, sodium metal reacts vigorously with air and catches fire / kerosene oil does not allow sodium to come in contact with air and catch fire.</p> <p>(c) Nitric acid is a strong oxidising agent. It oxidises the hydrogen produced in the reaction to water.</p>	1	
		1	
		1	3
28	<p>(a)</p> <ul style="list-style-type: none"> <li>(i) <b>Reduction Process- Roasting</b></li> </ul>	1/2	

	<p><b>Reason-</b> Mercury has low reactivity.</p> <p>(ii) <b>Reduction Process-</b> Roasting <b>Reason-</b> Copper has low reactivity.</p> <p>(iii) <b>Reduction Process-</b> Electrolytic Reduction. <b>Reason-</b> Sodium has high reactivity</p> <p style="text-align: center;"><b>OR</b></p> <p>(b)</p> <p>(i) <b>Change in appearance</b> - White to black colour. <b>Reason-</b> Silver sulphide is formed.</p> <p>(ii) <b>Change in appearance</b> – Reddish brown to green colour. <b>Reason-</b> Basic Copper Carbonate is formed.</p> <p>(iii) <b>Change in appearance-</b> Grey to brown colour. <b>Reason-</b> Rust (iron oxide) is formed.</p>	<p><math>\frac{1}{2}</math></p> <p><math>\frac{1}{2}</math></p> <p><math>\frac{1}{2}</math></p> <p><math>\frac{1}{2}</math></p> <p><math>\frac{1}{2} + \frac{1}{2}</math></p> <p><math>\frac{1}{2} + \frac{1}{2}</math></p> <p><math>\frac{1}{2} + \frac{1}{2}</math></p>	<p>3</p>
29	When water is lost through stomata in the leaves by transpiration, it creates a suction force/transpiration pull, due to which water is pulled up through xylem of the roots to the leaves.	1+1+1	3
30	<p>(a) Constituents:- Brain and Spinal cord.</p> <p>Protection:- Brain – Bony box/in skull/Cranium/fluid filled balloon. Spinal Cord – Vertebral column.</p> <p>(b) Limitations :</p> <p>(i) They will reach only those cells that are connected by nervous tissue, not each and every cell in the animal body.</p> <p>(ii) Once an electrical impulse is generated in a cell and transmitted, the cell will take some time to reset its mechanisms before it can generate and transmit a new impulse.</p> <p style="text-align: right;"><b>(Any other)</b></p>	<p><math>\frac{1}{2} + \frac{1}{2}</math></p> <p><math>\frac{1}{2}</math></p> <p><math>\frac{1}{2}</math></p> <p><math>\frac{1}{2}</math></p> <p><math>\frac{1}{2}</math></p>	3
31	<ul style="list-style-type: none"> <li>Scattering of light / Tyndall effect</li> <li>When a beam of light strikes fine particles of smoke, it is reflected diffusely and the path of the light becomes visible.</li> <li>Very fine particles scatter mainly blue light/short wavelength colours while the particles of larger size scatter longer wavelength colours.</li> </ul>	<p>1</p> <p>1</p> <p>1</p>	3
32	<ul style="list-style-type: none"> <li>It prevents damage to the appliances and the electrical circuit from overloading and short circuiting.</li> </ul>	1	



	<p>• Here <math>P = 3 \text{ kW} = 3000 \text{ W}</math>, <math>V = 220 \text{ V}</math>, <math>I = ?</math></p> <p><math>P = V I</math></p> <p><math>I = \frac{P}{V} = \frac{3000 \text{ W}}{220 \text{ V}} = 13.63 \text{ A}</math></p> <p><math>13.63 \text{ A} &gt; \text{Rating of fuse } 5 \text{ A}</math>, therefore fuse wire will melt and break the circuit.</p>	<p><math>\frac{1}{2}</math></p> <p>1</p> <p><math>\frac{1}{2}</math></p>	3
33	<p>(a) Ohm's Law – The potential difference, <math>V</math>, across the ends of a given metallic wire in an electric circuit is directly proportional to the current flowing through it, provided its temperature remains the same.</p> <p>Formula :- <math>\frac{1}{R_p} = \frac{1}{R_1} + \frac{1}{R_2} + \frac{1}{R_3}</math></p> <p>(b) <math>R + \frac{R}{2} = \frac{3R}{2}</math></p>	<p>1</p> <p>1</p> <p>1</p>	3
<b>SECTION D</b>			
34	<p>(a) (i)</p> <p>(1) Solution B</p> <p>(2) Solution C</p> <p>(3) Solution A</p> <p>(4) Solution D</p> <p>(5) Solution E</p> <p>Increasing Order of <math>H^+</math> ion concentration :- <math>C &lt; E &lt; D &lt; A &lt; B</math></p> <p>(ii) (1) Acidic salt : Ammonium chloride; <math>NH_4Cl</math>  <b>Parent Acid</b>-Hydrochloric acid /HCl  <b>Parent Base</b>- Ammonium hydroxide/(<math>NH_4OH</math>)</p> <p>(2) Basic salt : Sodium Carbonate; <math>Na_2CO_3</math>  <b>Parent Acid</b>-Carbonic acid / <math>H_2CO_3</math>  <b>Parent Base</b>- Sodium hydroxide/ NaOH</p> <p style="text-align: right;">( Or Any other)</p>	<p><math>\frac{1}{2} \times 5</math></p> <p><math>\frac{1}{2}</math></p> <p><math>\frac{1}{2}</math></p> <p><math>\frac{1}{2}</math></p> <p><math>\frac{1}{2}</math></p>	



	<b>OR</b>		
	<p>(b) Chlor – alkali process;</p> <ul style="list-style-type: none"> <li>When electricity is passed through NaCl (aq) it decomposes to form sodium hydroxide / <math>2\text{NaCl} + 2\text{H}_2\text{O} \rightarrow 2\text{NaOH} + \text{Cl}_2 + \text{H}_2</math></li> <li>X – <math>\text{Cl}_2</math> gas – at anode</li> <li>Y – <math>\text{H}_2</math> gas – at cathode</li> </ul> <p style="text-align: center;"><i>(award marks if explained by diagram)</i></p> <ul style="list-style-type: none"> <li>Z – Bleaching powder / <math>\text{CaOCl}_2</math> / Calcium Oxychloride</li> <li><math>\text{Ca}(\text{OH})_2 + \text{Cl}_2 \longrightarrow \text{CaOCl}_2 + \text{H}_2\text{O}</math> (Bleaching powder)</li> </ul>	<p>1</p> <p><math>\frac{1}{2}</math></p> <p><math>\frac{1}{2} + \frac{1}{2}</math></p> <p><math>\frac{1}{2} + \frac{1}{2}</math></p> <p><math>\frac{1}{2}</math></p> <p>1</p>	5
35	<p>(a)</p> <p>(i) • Spores are reproductive structures that detach from the parent and give rise to a new individual.</p> <ul style="list-style-type: none"> <li>Sporangium / Sporangia</li> <li>Covered by thick walls to protect them from unfavourable conditions.</li> <li>Rhizopus</li> </ul> <p>(ii)</p> <ul style="list-style-type: none"> <li>Plants which have lost the capacity to produce seeds.</li> <li>Plants bear flowers and fruits earlier so as to reduce time.</li> <li>To get genetically similar plants.</li> </ul> <p style="text-align: right;"><b>(Any two or any Other)</b></p> <ul style="list-style-type: none"> <li><b>Methods</b> Layering and Grafting</li> </ul> <p style="text-align: right;"><b>(Or any other)</b></p> <p style="text-align: center;"><b>OR</b></p> <p>(b)</p> <p>(i)</p> <ul style="list-style-type: none"> <li>A – Male Germ Cell/Male Gamete; B – Pollen tube; C – Female Germ Cell / Female Gamete.</li> <li>B carries A (male germ cell) and this germ cell fuses with C (female germ cell) to form a zygote.</li> <li>Significance: Zygote is capable of growing into a new plant.</li> </ul>	<p><math>\frac{1}{2}</math></p> <p><math>\frac{1}{2}</math></p> <p><math>\frac{1}{2}</math></p> <p><math>\frac{1}{2}</math></p> <p>1 + 1</p> <p>1</p> <p><math>\frac{1}{2} \times 3</math></p> <p>1</p> <p><math>\frac{1}{2}</math></p>	

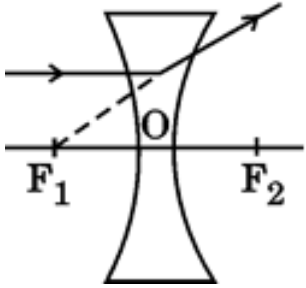
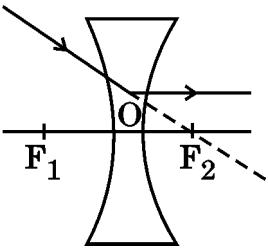

	<p>(ii) Post fertilisation changes: -</p> <ul style="list-style-type: none"> <li>• Zygote divides many times to form an embryo within ovule.</li> <li>• Ovule is converted into seed</li> <li>• Ovary ripens into fruit.</li> <li>• Petals, Sepals, Stamens, Style and Stigma may shrivel/dry and may fall off.</li> </ul>	½ x 4	5
36	<p>(a) (i)</p> <p>(1)</p>  <p>Fig.9.13(b)-Page-153, NCERT.</p> <p>(2)</p>  <p>Fig.9.14(b)-Page-154, NCERT.</p> <p><b>(Note:- Deduct half mark if directions of rays are not shown)</b></p> <p>(ii) Given <math>u = -16</math> cm, <math>f = +24</math> cm, <math>h = 4</math> cm</p> <p>Formula used <math>\frac{1}{v} - \frac{1}{u} = \frac{1}{f}</math></p> $\therefore \frac{1}{v} - \frac{1}{(-16)} = \frac{1}{+24}$ $\frac{1}{v} = \frac{-1}{48}$	1	1
		½	½



$$v = -48 \text{ cm}$$

Image is formed on the same side as the object

$$m = \frac{h'}{h} = \frac{v}{u}$$

$$\frac{h'}{4} = \frac{-48}{-16}$$

$$h' = 12 \text{ cm}$$

1

$\frac{1}{2}$

$\frac{1}{2}$

OR

(b) (i)

(1)

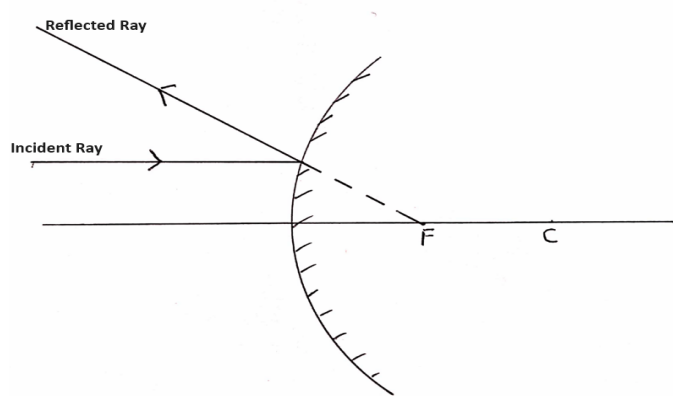

1

(2)

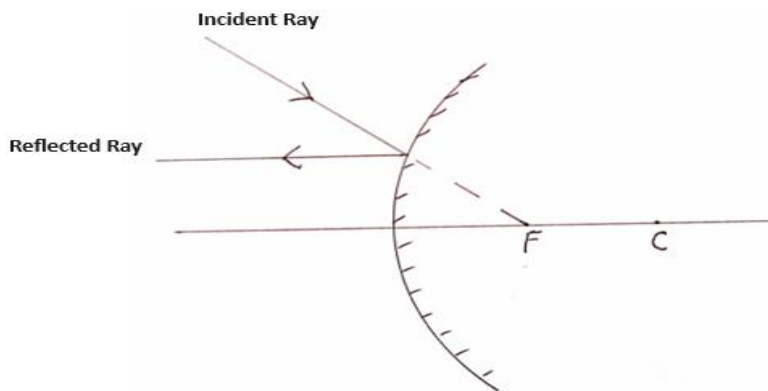

1

(Note:- Deduct half mark if directions of rays are not shown)

	(ii) Here $f = -12$ cm, $u = -18$ cm, $v = ?$ , $h = 1.5$ cm, $h' = ?$	$\frac{1}{2}$	
	Mirror formula $\frac{1}{v} + \frac{1}{u} = \frac{1}{f}$	$\frac{1}{2}$	
	$\therefore \frac{1}{v} = \frac{1}{f} - \frac{1}{u}$		5
	$= \frac{1}{-12 \text{ cm}} - \frac{1}{-18 \text{ cm}}$		
	$= \frac{-1}{36}$		
	$\therefore v = -36$ cm	1	
	$m = \frac{h'}{h} = -\frac{v}{u}$	$\frac{1}{2}$	
	$\frac{h'}{1.5} = -\frac{(-36)}{(-18)}$		
	$h' = -3.0$ cm	$\frac{1}{2}$	
<b>SECTION E</b>			
37	(a) <ul style="list-style-type: none"> <li>• <math>\text{CH}_3\text{Br}</math></li> <li>• <math>\text{C}_2\text{H}_5\text{Br}</math></li> </ul>	$\frac{1}{2}$ $\frac{1}{2}$	
	(b) (i) Aldehyde (ii) Ketone	$\frac{1}{2}$ $\frac{1}{2}$	
	(c) <ul style="list-style-type: none"> <li>• The colour of <math>\text{KMnO}_4</math> disappears;</li> <li>• <math>\text{KMnO}_4</math> acts as an oxidizing agent.</li> </ul>	$\frac{1}{2}$ $\frac{1}{2}$	
	<ul style="list-style-type: none"> <li>• <math>\text{CH}_3\text{CH}_2\text{OH} \xrightarrow{\text{Alkaline KMnO}_4 + \text{Heat}} \text{CH}_3\text{COOH}</math></li> </ul>	1	4
	<b>OR</b>		
	(c) <ul style="list-style-type: none"> <li>• Ethene Conc. <math>\text{H}_2\text{SO}_4</math> acts as a dehydrating agent.</li> </ul>	$\frac{1}{2}$ $\frac{1}{2}$	
	<ul style="list-style-type: none"> <li>• <math>\text{C}_2\text{H}_5\text{OH} \xrightarrow[443 \text{ K}]{\text{Conc. H}_2\text{SO}_4 + \text{Heat}} \text{CH}_2 = \text{CH}_2 + \text{H}_2\text{O}</math></li> </ul>	1	
38	(a) Salivary glands; Starch / Carbohydrate	$\frac{1}{2} + \frac{1}{2}$	



	<p>(b) Stomach, Anus</p> <p>(c)</p> <p>(i) The inner lining of the stomach will not be protected from the action of acid.</p> <p>(ii) Digested food will not be absorbed. / Absorption area will be reduced</p> <p style="text-align: center;"><b>OR</b></p> <p>(c)</p> <ul style="list-style-type: none"> <li>• Emulsification of fats.</li> <li>• Acidic medium has to be made alkaline for the pancreatic enzymes to act.</li> </ul>	<p><math>\frac{1}{2} + \frac{1}{2}</math></p> <p>1</p> <p>1</p> <p>1</p> <p>1</p>	4
39	<p>(a)</p> <p>(i) Bulb A glows</p> <p>(ii) Bulbs B, C, D and E glow</p> <p>(b) <math>P = V \times I</math>  <math>11 = 55 \times I</math>  <math>I = \frac{1}{5} = 0.2 \text{ amp}</math></p> <p>(c)</p> <p>(i) Resistance of bulb B, <math>R = \frac{V}{I} = \frac{55 \text{ V}}{0.2 \text{ A}} = 275 \Omega</math></p> <p style="text-align: center;"><b>(alternative formula for calculation <math>R = \frac{V^2}{P}</math>)</b></p> <p>(ii) Total resistance of the series combination of four bulbs  <math>= 4 \times 275 = 1100 \Omega</math></p> <p style="text-align: center;"><b>OR</b></p> <p>(c)</p> <ul style="list-style-type: none"> <li>• Bulb A will keep glowing with same brightness.</li> <li>• Other bulbs i.e., B, D and E will stop glowing.</li> </ul> <p>• <b>Reason:</b></p>	<p><math>\frac{1}{2}</math></p> <p><math>\frac{1}{2}</math></p> <p><math>\frac{1}{2}</math></p> <p><math>\frac{1}{2}</math></p> <p>1</p> <p>1</p> <p><math>\frac{1}{2}</math></p> <p><math>\frac{1}{2}</math></p>	



	As the bulbs B, D and E are connected in series with fused bulb C, so no current flows through them and thus they will not glow. The bulb A remains unaffected as it is connected in parallel combination.	1	4
--	--	---	---

\*\*\*

**Marking Scheme**  
**Strictly Confidential**  
**Secondary School Examination, 2024**  
**SUBJECT NAME SCIENCE (086) (Q.P. CODE 31/3/2)**

**General Instructions: -**

1	You are aware that evaluation is the most important process in the actual and correct assessment of the candidates. A small mistake in evaluation may lead to serious problems which may affect the future of the candidates, education system and teaching profession. To avoid mistakes, it is requested that before starting evaluation, you must read and understand the spot evaluation guidelines carefully.
2	“Evaluation policy is a confidential policy as it is related to the confidentiality of the examinations conducted, Evaluation done and several other aspects. Its’ leakage to public in any manner could lead to derailment of the examination system and affect the life and future of millions of candidates. Sharing this policy/document to anyone, publishing in any magazine and printing in News Paper/Website etc may invite action under various rules of the Board and IPC.”
3	Evaluation is to be done as per instructions provided in the Marking Scheme. It should not be done according to one’s own interpretation or any other consideration. Marking Scheme should be strictly adhered to and religiously followed. However, while evaluating, answers which are based on latest information or knowledge and/or are innovative, they may be assessed for their correctness otherwise and due marks be awarded to them. In class-X, while evaluating two competency-based questions, please try to understand given answer and even if reply is not from marking scheme but correct competency is enumerated by the candidate, due marks should be awarded.
4	The Marking scheme carries only suggested value points for the answers These are in the nature of Guidelines only and do not constitute the complete answer. The students can have their own expression and if the expression is correct, the due marks should be awarded accordingly.
5	The Head-Examiner must go through the first five answer books evaluated by each evaluator on the first day, to ensure that evaluation has been carried out as per the instructions given in the Marking Scheme. If there is any variation, the same should be zero after deliberation and discussion. The remaining answer books meant for evaluation shall be given only after ensuring that there is no significant variation in the marking of individual evaluators.
6	Evaluators will mark( ✓ ) wherever answer is correct. For wrong answer CROSS ‘X’ be marked. Evaluators will not put right (✓)while evaluating which gives an impression that answer is correct and no marks are awarded. This is most common mistake which evaluators are committing.
7	If a question has parts, please award marks on the right-hand side for each part. Marks awarded for different parts of the question should then be totaled up and written in the left-hand margin and encircled. This may be followed strictly.
8	If a question does not have any parts, marks must be awarded in the left-hand margin and encircled. This may also be followed strictly.
9	If a student has attempted an extra question, answer of the question deserving more marks should be retained and the other answer scored out with a note “Extra Question”.



10	No marks to be deducted for the cumulative effect of an error. It should be penalized only once.
11	A full scale of marks ___0-80_____ (example 0 to 80/70/60/50/40/30 marks as given in Question Paper) has to be used. Please do not hesitate to award full marks if the answer deserves it.
12	Every examiner has to necessarily do evaluation work for full working hours i.e., 8 hours every day and evaluate 20 answer books per day in main subjects and 25 answer books per day in other subjects (Details are given in Spot Guidelines). This is in view of the reduced syllabus and number of questions in question paper.
13	Ensure that you do not make the following common types of errors committed by the Examiner in the past:- Leaving answer or part thereof unassessed in an answer book. Giving more marks for an answer than assigned to it. Wrong totaling of marks awarded on an answer. Wrong transfer of marks from the inside pages of the answer book to the title page. Wrong question wise totaling on the title page. Wrong totaling of marks of the two columns on the title page. Wrong grand total. Marks in words and figures not tallying/not same. Wrong transfer of marks from the answer book to online award list. Answers marked as correct, but marks not awarded. (Ensure that the right tick mark is correctly and clearly indicated. It should merely be a line. Same is with the X for incorrect answer.) Half or a part of answer marked correct and the rest as wrong, but no marks awarded.
14	While evaluating the answer books if the answer is found to be totally incorrect, it should be marked as cross (X) and awarded zero (0) Marks.
15	Any unassessed portion, non-carrying over of marks to the title page, or totaling error detected by the candidate shall damage the prestige of all the personnel engaged in the evaluation work as also of the Board. Hence, in order to uphold the prestige of all concerned, it is again reiterated that the instructions be followed meticulously and judiciously.
16	The Examiners should acquaint themselves with the guidelines given in the “Guidelines for Spot Evaluation” before starting the actual evaluation.
17	Every Examiner shall also ensure that all the answers are evaluated, marks carried over to the title page, correctly totaled and written in figures and words.
18	The candidates are entitled to obtain photocopy of the Answer Book on request on payment of the prescribed processing fee. All Examiners/Additional Head Examiners/Head Examiners are once again reminded that they must ensure that evaluation is carried out strictly as per value points for each answer as given in the Marking Scheme.



**MARKING SCHEME**  
**Secondary School Examination, 2024**  
**SCIENCE (Subject Code–086)**  
**[ Paper Code: 31/3/2]**

**Maximum Marks: 80**

Q. No.	EXPECTED ANSWER / VALUE POINTS	Marks	Total Marks
<b>SECTION A</b>			
1	(A) / Washing Soda	1	1
2	(B) / $\text{CaO} + \text{H}_2\text{O} \rightarrow \text{Ca(OH)}_2$	1	1
3	(A) / Quick lime	1	1
4	(B) / Turmeric and litmus	1	1
5	(B) / $\text{C}_7\text{H}_{14}$	1	1
6	(C) / $\text{CH}_3\text{COOC}_2\text{H}_5 + \text{NaOH} \rightarrow \text{CH}_3\text{COONa} + \text{C}_2\text{H}_5\text{OH}$	1	1
7	(A) / 1, 6, 2 and 3	1	1
8	(D) / 4D and 2L	1	1
9	(D) / Reduce CFC production	1	1
10	(D) / They reproduce asexually	1	1
11	(A) / Tt and Tt	1	1
12	(C) / (b) and (c)	1	1
13	(C) / Petals only	1	1
14	(D) / Dispersion, refraction and internal reflection	1	1
15	(B) / (a) and (c)	1	1
16	(A) / 2 trophic levels	1	1
17	(A) / Both Assertion (A) and Reason (R) are true and Reason (R) is the correct explanation of Assertion (A)	1	1
18	(C) / Assertion (A) is true, but Reason (R) is false	1	1
19	(D) / Assertion (A) is false but Reason (R) is true.	1	1
20	(B) / Both Assertion (A) and Reason (R) are true, but Reason (R) is not the correct explanation of Assertion (A)	1	1
<b>SECTION B</b>			
21	(a) $\text{BaCl}_2(\text{aq}) + \text{Na}_2\text{SO}_4(\text{aq}) \rightarrow 2\text{NaCl}(\text{aq}) + \text{BaSO}_4(\text{s})$  (b) <ul style="list-style-type: none"> <li>• Double displacement reaction</li> <li>• As exchange of ions takes place</li> </ul>	1  $\frac{1}{2}$ $\frac{1}{2}$	2
22	<ul style="list-style-type: none"> <li>• When he can not see nearby objects distinctly but can see far object clearly.</li> <li>• 2 causes: Focal length of the eye lens is too long.</li> <li>• Eyeball becomes too small.</li> <li>• Convex or Converging lens</li> </ul>	$\frac{1}{2}$ $\frac{1}{2}$ $\frac{1}{2}$	2



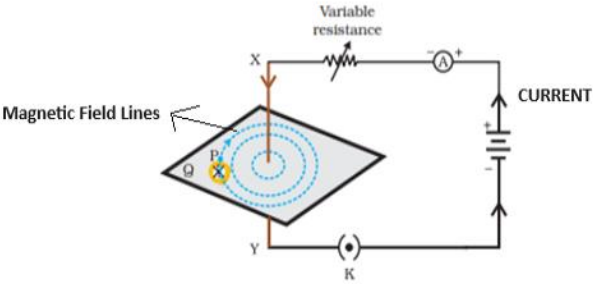
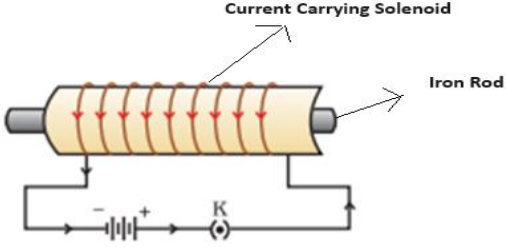

23	<p>(a)</p>  <p>Fig.12.6(a) on page 199-NCERT</p> <p style="text-align: right;"><b>Diagram:</b> <b>Directions of current and magnetic field:</b></p> <p style="text-align: center;"><b>OR</b></p> <p>(b)</p> <ul style="list-style-type: none"> <li>• Permanent magnet / Current carrying solenoid/ Electromagnet</li> <li>•</li> </ul>  <p>Fig-12.11, page no.201-NCERT</p> <p style="text-align: right;"><b>Diagram:</b> <b>Labelling:</b></p>	<p style="text-align: center;">1 1/2+1/2</p> <p style="text-align: center;">1/2</p> <p style="text-align: center;">1 1/2</p>	<p style="text-align: center;">2</p>
24	<ul style="list-style-type: none"> <li>• Synthesized at shoot tip/root tip</li> <li>• When light falls on one side of the plant, auxin diffuses towards the shady side of shoot. The concentration of auxin stimulates the cells to grow longer on the side of shoot which is away from light. Thus, plant appears bent towards light/phototropism.</li> </ul>	<p style="text-align: center;">1/2</p> <p style="text-align: center;">1 1/2</p>	<p style="text-align: center;">2</p>
25	<p>(a) 2 visible characters of garden pea plants are :</p> <ul style="list-style-type: none"> <li>• Tallness (dominant), Dwarfness (recessive)</li> <li>• Yellow seeds (dominant), Green seeds (recessive)</li> </ul> <p style="text-align: right;"><b>(Any other pair)</b></p>	<p style="text-align: center;">1/2 + 1/2</p> <p style="text-align: center;">1/2 + 1/2</p>	

	<p style="text-align: center;"><b>OR</b></p> <p>(b)</p>	2	1/2 1/2 1/2 1/2
26	<ul style="list-style-type: none"> <li>• Biodegradable – Substances that are broken down by biological processes.</li> <li>• Non-biodegradable – Substances that are not broken down by biological processes.</li> </ul> <p><b>Classification:-</b></p> <p>Biodegradable – Newspaper, Vegetable peels  Non-biodegradable – Glass bottles, Polythene bags</p>	1/2 1/2 1/2 1/2	2
<b>SECTION C</b>			
27	<p>(a)</p> <p>(i) <b>Reduction Process-</b> Roasting  <b>Reason-</b> Mercury has low reactivity.</p> <p>(ii) <b>Reduction Process-</b> Roasting  <b>Reason-</b> Copper has low reactivity.</p> <p>(iii) <b>Reduction Process-</b> Electrolytic Reduction.  <b>Reason-</b> Sodium has high reactivity</p> <p style="text-align: center;"><b>OR</b></p> <p>(b)</p> <p>(i) <b>Change in appearance</b> - White to black colour.  <b>Reason-</b> Silver sulphide is formed.</p>	1/2 1/2 1/2 1/2 1/2+1/2	

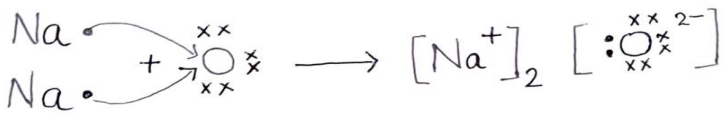
	<p>(ii) <b>Change in appearance</b> – Reddish brown to green colour. <b>Reason-</b> Basic Copper Carbonate is formed.</p> <p>(iii) <b>Change in appearance-</b> Grey to brown colour. <b>Reason-</b> Rust (iron oxide) is formed.</p>	<p><math>\frac{1}{2} + \frac{1}{2}</math></p> <p><math>\frac{1}{2} + \frac{1}{2}</math></p>	3				
28	<p>Na = 2, 8, 1; O = 2,6</p> <p>  </p> <ul style="list-style-type: none"> <li>Cation – Sodium</li> <li>Anion – Oxide</li> </ul>	<p><math>\frac{1}{2} + \frac{1}{2}</math></p> <p>1</p> <p><math>\frac{1}{2}</math></p> <p><math>\frac{1}{2}</math></p>	3				
29	<p>(a) Constituents:- Brain and Spinal cord.</p> <p>Protection:- Brain – Bony box/in skull/Cranium/fluid filled balloon Spinal Cord – Vertebral column.</p> <p>(b) Limitations :</p> <p>(i) They will reach only those cells that are connected by nervous tissue, not each and every cell in the animal body.</p> <p>(ii) Once an electrical impulse is generated in a cell and transmitted, the cell will take some time to reset its mechanisms before it can generate and transmit a new impulse. <b>(Any other)</b></p>	<p><math>\frac{1}{2} + \frac{1}{2}</math></p> <p><math>\frac{1}{2}</math></p> <p><math>\frac{1}{2}</math></p> <p><math>\frac{1}{2}</math></p> <p><math>\frac{1}{2}</math></p>	3				
30	<ul style="list-style-type: none"> <li>Difference :</li> </ul> <table border="1" data-bbox="154 1365 1096 1480"> <thead> <tr> <th>Aerobic Respiration</th> <th>Anaerobic Respiration</th> </tr> </thead> <tbody> <tr> <td>Utilises Oxygen</td> <td>Takes place in the absence of Oxygen</td> </tr> </tbody> </table> <p>Common pathway for aerobic and anaerobic respiration Glucose → Pyruvate Glucose → Pyruvate <math>\xrightarrow[\text{O}_2]{\text{Presence of}}</math> Carbon dioxide + Water + Energy Site – in mitochondria</p>	Aerobic Respiration	Anaerobic Respiration	Utilises Oxygen	Takes place in the absence of Oxygen	<p><math>\frac{1}{2} + \frac{1}{2}</math></p> <p><math>\frac{1}{2}</math></p> <p>1</p> <p><math>\frac{1}{2}</math></p>	3
Aerobic Respiration	Anaerobic Respiration						
Utilises Oxygen	Takes place in the absence of Oxygen						
31	<ul style="list-style-type: none"> <li>It prevents damage to the appliances and the electrical circuit from overloading and short circuiting.</li> </ul>	1					

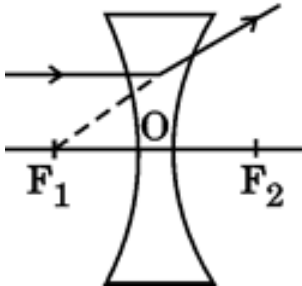
	<p>Here <math>P = 3 \text{ kW} = 3000 \text{ W}</math>, <math>V = 220 \text{ V}</math>, <math>I = ?</math></p> <p><math>P = V I</math></p> <p><math>I = \frac{P}{V} = \frac{3000 \text{ W}}{220 \text{ V}} = 13.63 \text{ A}</math></p> <p><math>13.63 \text{ A} &gt;</math> Rating of fuse <math>5 \text{ A}</math>, therefore fuse wire will melt and break the circuit.</p>	<p><math>\frac{1}{2}</math></p> <p>1</p> <p><math>\frac{1}{2}</math></p>	<p>3</p>
32	<ul style="list-style-type: none"> <li>• Scattering of light / Tyndall effect</li> <li>• When a beam of light strikes fine particles of smoke, it is reflected diffusely and the path of the light becomes visible.</li> <li>• Very fine particles scatter mainly blue light/short wavelength colours while the particles of larger size scatter longer wavelength colours.</li> </ul>	<p>1</p> <p>1</p> <p>1</p>	<p>3</p>
33	<ul style="list-style-type: none"> <li>• Each electrical appliance has its own switch due to which each one can be turned ON and OFF separately, as per their requirement.</li> <li>• If due to some defect one electrical appliance stops working, then all other appliances keep working.</li> <li>• Each appliance has equal potential difference and draws the required amount of current.</li> <li>• The total resistance in a parallel circuit is decreased.</li> </ul> <p style="text-align: right;"><b>(Any three)</b></p>	<p>1</p> <p>1</p> <p>1</p>	<p>3</p>
<b>SECTION E</b>			
34	<p>(a) (i)</p> <p>(1)</p>  <p>Fig.9.13(b)-Page-153, NCERT.</p>	<p>1</p>	



(2)

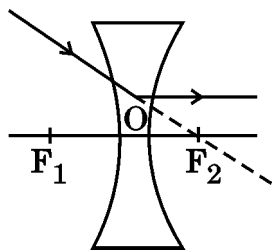

Fig.9.14(b)-Page-154, NCERT.

(Note:- Deduct half mark if directions of rays are not shown)

1

(ii) Given  $u = -16$  cm,  $f = +24$  cm,  $h = 4$  cm

Formula used  $\frac{1}{v} - \frac{1}{u} = \frac{1}{f}$

$$\therefore \frac{1}{v} - \frac{1}{(-16)} = \frac{1}{+24}$$

$$\frac{1}{v} = \frac{-1}{48}$$

$$v = -48 \text{ cm}$$

$\frac{1}{2}$

$\frac{1}{2}$

1

Image is formed on the same side as the object

$$m = \frac{h'}{h} = \frac{v}{u}$$

$$\frac{h'}{4} = \frac{-48}{-16}$$

$$h' = 12 \text{ cm}$$

**OR**

$\frac{1}{2}$

5

$\frac{1}{2}$

(b) (i)

(1)

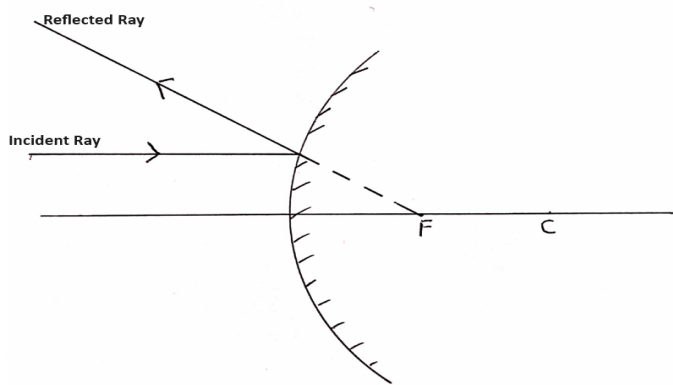

1



(2)

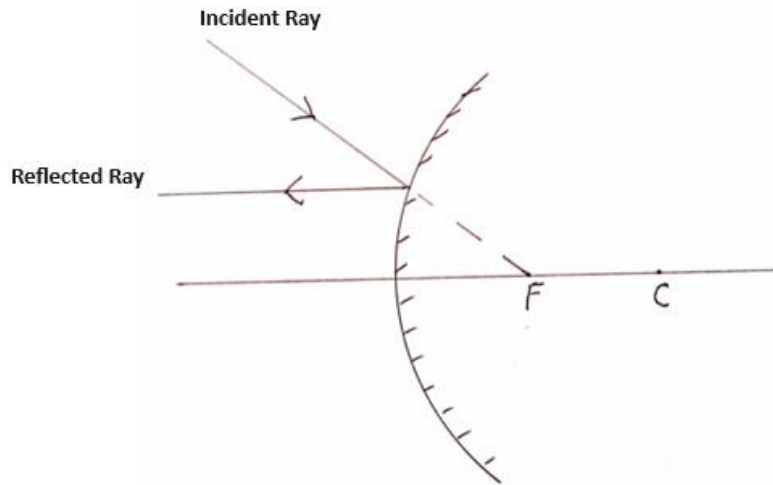

(Note:- Deduct half mark if directions of rays are not shown)

(ii) Here  $f = -12$  cm,  $u = -18$  cm,  $v = ?$ ,  $h = 1.5$  cm,  $h' = ?$

Mirror formula  $\frac{1}{v} + \frac{1}{u} = \frac{1}{f}$

$$\therefore \frac{1}{v} = \frac{1}{f} - \frac{1}{u}$$

$$= \frac{1}{-12 \text{ cm}} - \frac{1}{-18 \text{ cm}}$$

$$= \frac{-1}{36}$$

$$\therefore v = -36 \text{ cm}$$

$$m = \frac{h'}{h} = -\frac{v}{u}$$

$$\frac{h'}{1.5} = -\frac{(-36)}{(-18)}$$

$$h' = -3.0 \text{ cm}$$

1

$\frac{1}{2}$

$\frac{1}{2}$

1

$\frac{1}{2}$

$\frac{1}{2}$



35	<p>(a)</p> <ul style="list-style-type: none"> <li>• When the rate of general body growth begins to slow down and reproductive tissue begins to mature.</li> <li>• In boys – New thick hair growth on face, voice begins to crack, penis begins to enlarge and become erect.</li> </ul> <p style="text-align: right;"><b>(Any two)</b></p> <p>(b) Testis – Formation of sperms, Secretion of hormone testosterone</p> <p>Role of :</p> <p>(i) Vas deferens – Delivery of sperms from testes to urethra.</p> <p>(ii) Seminal vesicle – Provides nutrition to sperms /makes the transport(movement) of sperms easier.</p> <p>(iii) Urethra – Common passage for sperms and urine.</p> <p>(iv) Scrotum – Providing required temperature for sperm formation</p>	<p>1</p> <p><math>\frac{1}{2} + \frac{1}{2}</math></p> <p><math>\frac{1}{2}</math> <math>\frac{1}{2}</math></p> <p><math>\frac{1}{2} \times 4</math></p>	
<b>OR</b>			
	<p>(a) (i) Ovary –</p> <ul style="list-style-type: none"> <li>• Production of Estrogen hormone</li> <li>• Production of female gamete /egg</li> </ul> <p>(ii) Oviduct –</p> <ul style="list-style-type: none"> <li>• Transfer of female gamete from the ovary to uterus</li> <li>• Site of fertilisation</li> </ul> <p>(iii) Uterus –</p> <ul style="list-style-type: none"> <li>• Implantation of zygote</li> <li>• Nourishment of the developing embryo</li> </ul> <p>(b) Structure of Placenta –</p> <ul style="list-style-type: none"> <li>• Disc like structure embedded in the uterine wall connected to the embryo.</li> <li>• It has villi on the embryo's side and blood spaces on the mother's side.</li> </ul>	<p><math>\frac{1}{2}</math></p> <p><math>\frac{1}{2}</math></p> <p><math>\frac{1}{2}</math></p> <p><math>\frac{1}{2}</math></p> <p><math>\frac{1}{2}</math></p> <p><math>\frac{1}{2}</math></p> <p><math>\frac{1}{2} \times 2</math></p>	5

	<p><b>Function :</b></p> <ul style="list-style-type: none"> <li>Provides a large surface area for nutrients (glucose and oxygen) to pass from the mother's side to embryo, waste substances from embryo's side to mother's blood.</li> </ul>	1	
36	<p>(a) (i)</p> <p>(1) Solution B (2) Solution C (3) Solution A (4) Solution D (5) Solution E</p> <p>Increasing Order of H<sup>+</sup> ion concentration – C &lt; E &lt; D &lt; A &lt; B</p> <p>(ii)(1) Acidic salt : (Ammonium chloride) NH<sub>4</sub>Cl  <b>Parent Acid</b>-Hydrochloric acid /HCl  <b>Parent Base</b>- Ammonium hydroxide/(NH<sub>4</sub>OH)</p> <p>(2) Basic salt : (Sodium Carbonate) Na<sub>2</sub>CO<sub>3</sub>  <b>Parent Acid</b>-Carbonic acid / H<sub>2</sub>CO<sub>3</sub>  <b>Parent Base</b>- Sodium hydroxide / NaOH</p> <p style="text-align: right;"><b>( Or Any other)</b></p> <p style="text-align: center;"><b>OR</b></p> <p>(b) Chlor – alkali process;</p> <ul style="list-style-type: none"> <li>When electricity is passed through NaCl (aq) it decomposes to form sodium hydroxide / <math>2\text{NaCl} + 2\text{H}_2\text{O} \rightarrow 2\text{NaOH} + \text{Cl}_2 + \text{H}_2</math></li> <li>X – Cl<sub>2</sub> gas – at anode</li> <li>Y – H<sub>2</sub> gas – at cathode</li> </ul> <p style="text-align: right;"><i>(award marks if explained by diagram)</i></p> <ul style="list-style-type: none"> <li>Z – Bleaching powder / CaOCl<sub>2</sub> / Calcium Oxychloride</li> <li><math>\text{Ca}(\text{OH})_2 + \text{Cl}_2 \longrightarrow \text{CaOCl}_2 + \text{H}_2\text{O}</math> (Bleaching powder)</li> </ul>	<p>1/2 x 5</p> <p>1/2</p> <p>1/2</p> <p>1/2</p> <p>1/2</p> <p>1</p> <p>1/2</p> <p>1/2 + 1/2</p> <p>1/2 + 1/2</p> <p>1/2</p> <p>1</p>	5
<b>SECTION E</b>			
37	<p>(a)</p> <ul style="list-style-type: none"> <li>CH<sub>3</sub>Br</li> <li>C<sub>2</sub>H<sub>5</sub>Br</li> </ul> <p>(b)</p> <p>(i) Aldehyde</p> <p>(ii) Ketone</p>	<p>1/2</p> <p>1/2</p> <p>1/2</p> <p>1/2</p>	



	<p>(c)</p> <ul style="list-style-type: none"> <li>The colour of <math>\text{KMnO}_4</math> disappears;</li> <li><math>\text{KMnO}_4</math> acts as an oxidizing agent.</li> <li><math>\text{CH}_3\text{CH}_2\text{OH} \xrightarrow{\text{Alkaline KMnO}_4 + \text{Heat}} \text{CH}_3\text{COOH}</math></li> </ul> <p style="text-align: center;"><b>OR</b></p> <p>(c)</p> <ul style="list-style-type: none"> <li>Ethene</li> <li>Conc. <math>\text{H}_2\text{SO}_4</math> acts as a dehydrating agent.</li> <li><math>\text{C}_2\text{H}_5\text{OH} \xrightarrow[443 \text{ K}]{\text{Conc. H}_2\text{SO}_4 + \text{Heat}} \text{CH}_2 = \text{CH}_2 + \text{H}_2\text{O}</math></li> </ul>	<p><math>\frac{1}{2}</math></p> <p><math>\frac{1}{2}</math></p> <p>1</p> <p><math>\frac{1}{2}</math></p> <p><math>\frac{1}{2}</math></p> <p>1</p>	4
38	<p>(a) Salivary glands; Starch / Carbohydrate</p> <p>(b) Stomach, Anus</p> <p>(c)</p> <p>(i) The inner lining of the stomach will not be protected from the action of acid.</p> <p>(ii) Digested food will not be absorbed / Absorption area will be reduced.</p> <p style="text-align: center;"><b>OR</b></p> <p>(c)</p> <ul style="list-style-type: none"> <li>Emulsification of fats.</li> <li>Acidic medium has to be made alkaline for the pancreatic enzymes to act.</li> </ul>	<p><math>\frac{1}{2} + \frac{1}{2}</math></p> <p><math>\frac{1}{2} + \frac{1}{2}</math></p> <p>1</p> <p>1</p> <p>1</p> <p>1</p>	4
39	<p>(a)</p> <p>(i) Bulb A glows</p> <p>(ii) Bulbs B, C, D and E glow</p> <p>(b) <math>P = V \times I</math>  <math>11 = 55 \times I</math>  <math>I = \frac{1}{5} = 0.2 \text{ amp}</math></p> <p>(c)</p> <p>(i) Resistance of bulb B, <math>R = \frac{V}{I} = \frac{55 \text{ V}}{0.2 \text{ A}} = 275 \Omega</math></p> <p>(alternative formula for calculation <math>R = \frac{V^2}{P}</math>)</p>	<p><math>\frac{1}{2}</math></p> <p><math>\frac{1}{2}</math></p> <p><math>\frac{1}{2}</math></p> <p><math>\frac{1}{2}</math></p> <p>1</p>	



	<p>(ii) Total resistance of the series combination of four bulbs  <math>= 4 \times 275 = 1100 \Omega</math></p> <p style="text-align: center;"><b>OR</b></p> <p>(c)</p> <ul style="list-style-type: none"> <li>• Bulb A will keep glowing with same brightness.</li> <li>• Other bulbs i.e., B, D and E will stop glowing.</li> </ul> <p>Reason:</p> <p>As the bulbs B, D and E are connected in series with fused bulb C, so no current flows through them and thus they will not glow. The bulb A remains unaffected as it is connected in parallel combination.</p>	<p style="text-align: center;">1</p> <p style="text-align: center;"><math>\frac{1}{2}</math></p> <p style="text-align: center;"><math>\frac{1}{2}</math></p> <p style="text-align: center;">1</p>	<p style="text-align: center;">4</p>
--	--	---	--------------------------------------

\*\*\*\*\*

**Marking Scheme**  
**Strictly Confidential**  
**Secondary School Examination, 2024**  
**SUBJECT NAME SCIENCE (086) (Q.P. CODE 31/3/3)**

General Instructions: -

1	You are aware that evaluation is the most important process in the actual and correct assessment of the candidates. A small mistake in evaluation may lead to serious problems which may affect the future of the candidates, education system and teaching profession. To avoid mistakes, it is requested that before starting evaluation, you must read and understand the spot evaluation guidelines carefully.
2	“Evaluation policy is a confidential policy as it is related to the confidentiality of the examinations conducted, Evaluation done and several other aspects. Its’ leakage to public in any manner could lead to derailment of the examination system and affect the life and future of millions of candidates. Sharing this policy/document to anyone, publishing in any magazine and printing in News Paper/Website etc may invite action under various rules of the Board and IPC.”
3	Evaluation is to be done as per instructions provided in the Marking Scheme. It should not be done according to one’s own interpretation or any other consideration. Marking Scheme should be strictly adhered to and religiously followed. However, while evaluating, answers which are based on latest information or knowledge and/or are innovative, they may be assessed for their correctness otherwise and due marks be awarded to them. In class-X, while evaluating two competency-based questions, please try to understand given answer and even if reply is not from marking scheme but correct competency is enumerated by the candidate, due marks should be awarded.
4	The Marking scheme carries only suggested value points for the answers These are in the nature of Guidelines only and do not constitute the complete answer. The students can have their own expression and if the expression is correct, the due marks should be awarded accordingly.
5	The Head-Examiner must go through the first five answer books evaluated by each evaluator on the first day, to ensure that evaluation has been carried out as per the instructions given in the Marking Scheme. If there is any variation, the same should be zero after deliberation and discussion. The remaining answer books meant for evaluation shall be given only after ensuring that there is no significant variation in the marking of individual evaluators.
6	Evaluators will mark(√) wherever answer is correct. For wrong answer CROSS ‘X’ be marked. Evaluators will not put right (√)while evaluating which gives an impression that answer is correct and no marks are awarded. This is most common mistake which evaluators are committing.
7	If a question has parts, please award marks on the right-hand side for each part. Marks awarded for different parts of the question should then be totaled up and written in the left-hand margin and encircled. This may be followed strictly.
8	If a question does not have any parts, marks must be awarded in the left-hand margin and encircled. This may also be followed strictly.
9	If a student has attempted an extra question, answer of the question deserving more marks should be retained and the other answer scored out with a note “Extra Question”.

10	No marks to be deducted for the cumulative effect of an error. It should be penalized only once.
11	A full scale of marks ___0-80_____ (example 0 to 80/70/60/50/40/30 marks as given in Question Paper) has to be used. Please do not hesitate to award full marks if the answer deserves it.
12	Every examiner has to necessarily do evaluation work for full working hours i.e., 8 hours every day and evaluate 20 answer books per day in main subjects and 25 answer books per day in other subjects (Details are given in Spot Guidelines). This is in view of the reduced syllabus and number of questions in question paper.
13	Ensure that you do not make the following common types of errors committed by the Examiner in the past:- Leaving answer or part thereof unassessed in an answer book. Giving more marks for an answer than assigned to it. Wrong totaling of marks awarded on an answer. Wrong transfer of marks from the inside pages of the answer book to the title page. Wrong question wise totaling on the title page. Wrong totaling of marks of the two columns on the title page. Wrong grand total. Marks in words and figures not tallying/not same. Wrong transfer of marks from the answer book to online award list. Answers marked as correct, but marks not awarded. (Ensure that the right tick mark is correctly and clearly indicated. It should merely be a line. Same is with the X for incorrect answer.) Half or a part of answer marked correct and the rest as wrong, but no marks awarded.
14	While evaluating the answer books if the answer is found to be totally incorrect, it should be marked as cross (X) and awarded zero (0) Marks.
15	Any unassessed portion, non-carrying over of marks to the title page, or totaling error detected by the candidate shall damage the prestige of all the personnel engaged in the evaluation work as also of the Board. Hence, in order to uphold the prestige of all concerned, it is again reiterated that the instructions be followed meticulously and judiciously.
16	The Examiners should acquaint themselves with the guidelines given in the “Guidelines for Spot Evaluation” before starting the actual evaluation.
17	Every Examiner shall also ensure that all the answers are evaluated, marks carried over to the title page, correctly totaled and written in figures and words.
18	The candidates are entitled to obtain photocopy of the Answer Book on request on payment of the prescribed processing fee. All Examiners/Additional Head Examiners/Head Examiners are once again reminded that they must ensure that evaluation is carried out strictly as per value points for each answer as given in the Marking Scheme.



**MARKING SCHEME**  
**Secondary School Examination, 2024**  
**SCIENCE (Subject Code–086)**  
**[ Paper Code: 31/3/3]**

**Maximum Marks: 80**

Q. No.	EXPECTED ANSWER / VALUE POINTS	Mark s	Total Mark s
<b>SECTION A</b>			
1	(B) / $\text{CaO} + \text{H}_2\text{O} \rightarrow \text{Ca(OH)}_2$	1	1
2	(A) / Quick lime	1	1
3	(B) / Turmeric and litmus	1	1
4	(A) / Washing Soda	1	1
5	(D) / $\text{NO}_2$ , PbO and $\text{O}_2$	1	1
6	(D) / Butyne, Ethene, Propyne	1	1
7	(B)	1	1
8	(C) / (b) and (c)	1	1
9	(C) / 9 : 3 : 3 : 1	1	1
10	(D) / Cytokinins	1	1
11	(C) / Genetic material is contributed by two individuals of same species to produce a new generation.	1	1
12	(C) / Reptiles	1	1
13	(D) / 4D and 2L	1	1
14	(D) / $1 \Omega$	1	1
15	(B) / (a) and (c)	1	1
16	(A) / 2 trophic levels	1	1
17	(C) / Assertion (A) is true, but Reason (R) is false	1	1
18	(C) / Assertion (A) is true, but Reason (R) is false	1	1
19	(A) / Both Assertion (A) and Reason (R) are true, and Reason (R) is the correct explanation of Assertion (A)	1	1
20	(B) / Both Assertion (A) and Reason (R) are true and Reason (R) is not the correct explanation of Assertion (A)	1	1
<b>SECTION B</b>			
21	(a) Presence of Sunlight Decomposition reaction / Photochemical reaction.	$\frac{1}{2}$ $\frac{1}{2}$	2
	(b) $2\text{FeSO}_4(\text{s}) \xrightarrow{\text{Heat}} \text{Fe}_2\text{O}_3(\text{s}) + \text{SO}_2(\text{g}) + \text{SO}_3(\text{g})$	1	
22	(a) 2 visible characters of garden pea plants are:  <ul style="list-style-type: none"> <li>• Tallness (dominant), Dwarfness (recessive)</li> <li>• Yellow seeds (dominant), Green seeds (recessive)</li> </ul> <p style="text-align: right;">( Any other pair )</p>	$\frac{1}{2} + \frac{1}{2}$ $\frac{1}{2} + \frac{1}{2}$	

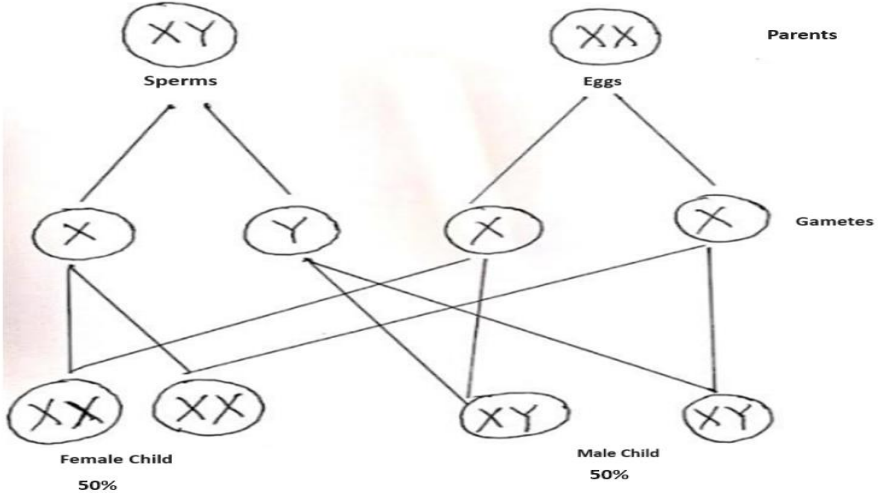
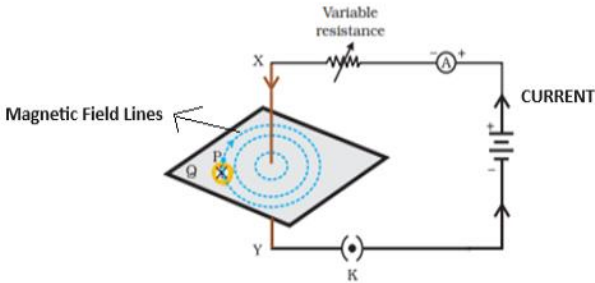
	<p style="text-align: center;"><b>OR</b></p> <p>(b)</p> 	<p style="text-align: center;">1/2</p> <p style="text-align: center;">1/2</p> <p style="text-align: center;">1/2</p> <p style="text-align: center;">1/2</p>	2
23	<ul style="list-style-type: none"> <li>• Synthesized at shoot tip/root tip</li> <li>• When light falls on one side of the plant, auxin diffuses towards the shady side of shoot. The concentration of auxin stimulates the cells to grow longer on the side of shoot which is away from light. Thus plant appears bent towards light/phototropism.</li> </ul>	<p style="text-align: center;">1/2</p> <p style="text-align: center;">1 1/2</p>	2
24	<p>(a)</p>  <p style="text-align: center;">Fig.12.6(a), on page 199-NCERT</p> <p style="text-align: right;"><b>Diagram:</b></p> <p style="text-align: center;"><b>Directions of current and magnetic field:</b></p> <p style="text-align: center;"><b>OR</b></p> <p>(b)</p> <ul style="list-style-type: none"> <li>• Permanent magnet / Current carrying solenoid/ Electromagnet</li> </ul>	<p style="text-align: center;">1</p> <p style="text-align: center;">1/2+1/2</p> <p style="text-align: center;">1/2</p>	2

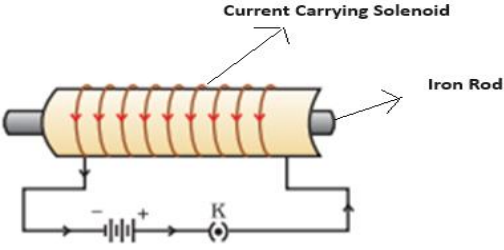
	<p style="text-align: center;">  </p> <p style="text-align: center;">Fig-12.11, page no.201-NCERT</p> <p style="text-align: right;"><b>Diagram:</b> <b>Labelling:</b></p>	1 ½	
25	<ul style="list-style-type: none"> <li>• When he cannot see nearby objects distinctly but can see far object clearly.</li> <li>• <b>2 causes:</b> Focal length of the eye lens is too long. Eyeball becomes too small.</li> <li>• Convex or Converging lens</li> </ul>	½  ½ ½ ½	2
26	<p>(a) Greater number of alternatives in the form of variety of organisms available at each trophic level in an ecosystem.</p> <p>(b) The available energy keeps on decreasing at each trophic level according to 10 percent law. So more trophic levels lead to less energy at the last trophic level which is not enough for the organisms to survive.</p>	1  1	2
<b>SECTION C</b>			
27	<p>(a)</p> <ul style="list-style-type: none"> <li>• Thermit reaction</li> <li>• <math>\text{Fe}_2\text{O}_3(\text{s}) + 2\text{Al}(\text{s}) \rightarrow 2\text{Fe}(\text{l}) + \text{Al}_2\text{O}_3(\text{s}) + \text{Heat}</math></li> <li>• Because Al being more reactive than Fe, it displaces Fe in <math>\text{Fe}_2\text{O}_3</math></li> <li>• This reaction is used to join railway tracks / cracked machine parts.</li> </ul> <p style="text-align: center;"><b>OR</b></p> <p>(b)</p> <p>(i) 'E' – Sodium (Na) / Potassium(K)</p> <p>(ii)</p> <ul style="list-style-type: none"> <li>• In water – <math>2\text{Na}(\text{s}) + 2\text{H}_2\text{O}(\text{l}) \rightarrow 2\text{NaOH}(\text{aq}) + \text{H}_2(\text{g}) + \text{heat energy}</math></li> </ul>	½ 1  1 ½    ½   1	

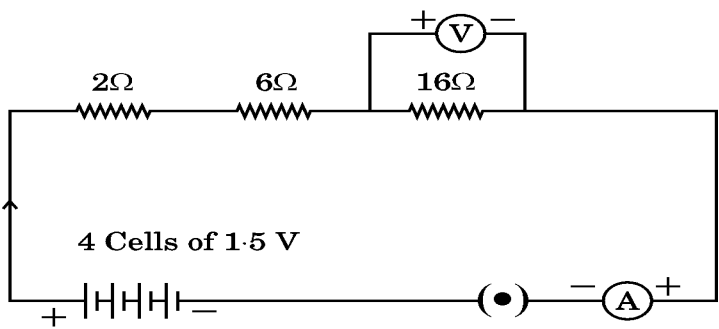
	<ul style="list-style-type: none"> <li>Nature of the product – Basic</li> </ul> (iii) Electrolytic reduction	$\frac{1}{2}$ 1	3
28	(a) Amphoteric oxide (zinc oxide) reacts with acids as well as bases to produce salt and water. (b) Bubbles of hydrogen gas which are formed during the reaction stick to the surface of calcium metal and make it lighter. (c) Nitric acid is a strong oxidising agent. It oxidises the hydrogen produced in the reaction to water.	1 1 1	3
29	When water is lost through stomata in the leaves by transpiration, it creates a suction force/transpiration pull, due to which water is pulled up through xylem of the roots to the leaves.	1+1+1	3
30	<ul style="list-style-type: none"> <li>Name:- Adrenaline</li> <li>Location:- Adrenal gland</li> <li>Responses :</li> </ul> Heart beats faster resulting in supply of more oxygen to our muscles. Blood to the digestive system is reduced due to contraction of muscles around small arteries. Breathing rate increases due to the contractions of diaphragm and rib muscles.	$\frac{1}{2}$ $\frac{1}{2}$ 2	3
31	<ul style="list-style-type: none"> <li>It prevents damage to the appliances and the electrical circuit from overloading and short circuiting.</li> </ul> <ul style="list-style-type: none"> <li>Here <math>P = 3 \text{ kW} = 3000 \text{ W}</math>, <math>V = 220 \text{ V}</math>, <math>I = ?</math></li> </ul> $P = V I$ $I = \frac{P}{V} = \frac{3000 \text{ W}}{220 \text{ V}} = 13.63 \text{ A}$ $13.63 \text{ A} > \text{Rating of fuse } 5 \text{ A, therefore fuse wire will melt and break the circuit.}$	1  $\frac{1}{2}$ 1  $\frac{1}{2}$	3
32	<ul style="list-style-type: none"> <li>  </li> </ul> (a) Current $(I) = \frac{V}{R} = \frac{4 \times 1.5 \text{ V}}{2\Omega + 6\Omega + 16\Omega} = \frac{6 \text{ V}}{24\Omega} = \frac{1}{4} \text{ A}$	1  1	







Formula used  $\frac{1}{v} - \frac{1}{u} = \frac{1}{f}$

$$\therefore \frac{1}{v} - \frac{1}{(-16)} = \frac{1}{+24}$$

$$\frac{1}{v} = \frac{-1}{48}$$

$$v = -48 \text{ cm}$$

Image is formed on the same side as the object

$$m = \frac{h'}{h} = \frac{v}{u}$$

$$\frac{h'}{4} = \frac{-48}{-16}$$

$$h' = 12 \text{ cm}$$

**OR**

(b) (i)  
(1)

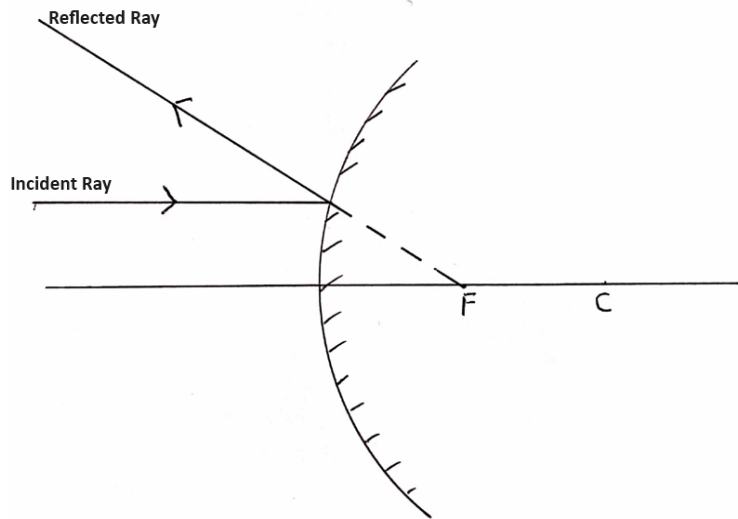

1/2

1

1/2

1/2

5

1



(2)

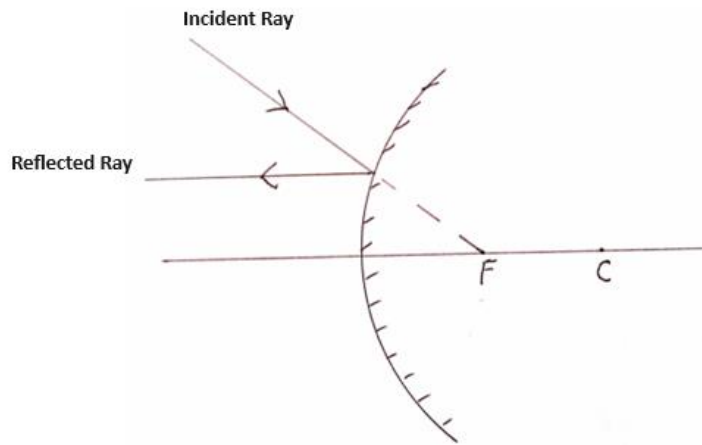

1

**(Note:- Deduct half mark if directions of rays are not shown)**

(ii) Here  $f = -12$  cm,  $u = -18$  cm,  $v = ?$ ,  $h = 1.5$  cm,  $h' = ?$

$\frac{1}{2}$

Mirror formula  $\frac{1}{v} + \frac{1}{u} = \frac{1}{f}$

$\frac{1}{2}$

$$\therefore \frac{1}{v} = \frac{1}{f} - \frac{1}{u}$$

$$= \frac{1}{-12 \text{ cm}} - \frac{1}{-18 \text{ cm}}$$

$$= \frac{-1}{36}$$

$$\therefore v = -36 \text{ cm}$$

1

$$m = \frac{h'}{h} = -\frac{v}{u}$$

$\frac{1}{2}$

$$\frac{h'}{1.5} = -\frac{(-36)}{(-18)}$$

$$h' = -3.0 \text{ cm}$$

$\frac{1}{2}$



35	<p>(a) Gonorrhoea, Syphilis, AIDS, Warts <b>(Any two)</b></p> <p>(b) Because child sex ratio is declining/ due to reckless female foeticide.</p> <p>(c)</p> <p>(i) Oral pills/ Chemical method ; change the hormonal balance of the body.</p> <p>(ii) Copper – T or loop; irritation of the uterus.</p> <p>(iii) Surgical method; can cause infections.</p> <p style="text-align: center;"><b>OR</b></p> <p>(a) Unisexual – Papaya / Watermelon Bisexual – Hibiscus / Mustard</p> <p>(b) The transfer of pollen grains from anther of one flower to stigma of another flower is called cross – pollination.</p> <p>Transfer of pollen grains is carried out by some pollinating agents like wind, water and animals.</p> <p>(c) A → Plumule – Future shoot B → Radicle – Future root</p> <p>*Refer fig. 7.9 Page 121 for diagram</p>	<p><math>\frac{1}{2} + \frac{1}{2}</math></p> <p>1</p> <p><math>\frac{1}{2} \times 6</math></p> <p><math>\frac{1}{2}</math></p> <p><math>\frac{1}{2}</math></p> <p>1</p> <p>1</p> <p><math>\frac{1}{2} \times 4</math></p>	5
36	<p>(a) (i)</p> <p>(1) Solution B</p> <p>(2) Solution C</p> <p>(3) Solution A</p> <p>(4) Solution D</p> <p>(5) Solution E</p> <p>Increasing Order of <math>H^+</math> ion concentration – <math>C &lt; E &lt; D &lt; A &lt; B</math></p> <p>(ii) (1) Acidic salt : (Ammonium chloride) <math>NH_4Cl</math> <b>Parent Acid</b>-Hydrochloric acid /HCl <b>Parent Base</b>- Ammonium hydroxide/(<math>NH_4OH</math>)</p> <p>(2) Basic salt : (Sodium Carbonate) <math>Na_2CO_3</math> <b>Parent Acid</b>-Carbonic acid / <math>H_2CO_3</math> <b>Parent Base</b>- Sodium hydroxide / NaOH</p> <p style="text-align: right;"><b>( Or Any other)</b></p>	<p><math>\frac{1}{2} \times 5</math></p> <p><math>\frac{1}{2}</math></p> <p><math>\frac{1}{2}</math></p> <p><math>\frac{1}{2}</math></p> <p><math>\frac{1}{2}</math></p>	5



	<b>OR</b>		
	(b) Chlor – alkali process; <ul style="list-style-type: none"> <li>When electricity is passed through NaCl (aq) it decomposes to form sodium hydroxide. <math>2\text{NaCl} + 2\text{H}_2\text{O} \rightarrow 2\text{NaOH} + \text{Cl}_2 + \text{H}_2</math></li> <li>X – Cl<sub>2</sub> gas – at anode</li> <li>Y – H<sub>2</sub> gas – at cathode</li> </ul> <p style="text-align: center;"><i>(award marks if explained by diagram)</i></p> <ul style="list-style-type: none"> <li>Z – Bleaching powder / CaOCl<sub>2</sub> / Calcium Oxychloride</li> <li><math>\text{Ca}(\text{OH})_2 + \text{Cl}_2 \rightarrow \text{CaOCl}_2 + \text{H}_2\text{O}</math> (Bleaching powder)</li> </ul>	1 ½  ½+ ½ ½ + ½  ½ 1	
	<b>SECTION E</b>		
37	(a) <ul style="list-style-type: none"> <li>CH<sub>3</sub>Br</li> <li>C<sub>2</sub>H<sub>5</sub>Br</li> </ul> (b) <ol style="list-style-type: none"> <li>Aldehyde</li> <li>Ketone</li> </ol> (c) <ul style="list-style-type: none"> <li>The colour of KMnO<sub>4</sub> disappears;</li> <li>KMnO<sub>4</sub> acts as an oxidizing agent.</li> <li><math>\text{CH}_3\text{CH}_2\text{OH} \xrightarrow{\text{Alkaline KMnO}_4 + \text{Heat}} \text{CH}_3\text{COOH}</math></li> </ul> <p style="text-align: center;"><b>OR</b></p> (c) <ul style="list-style-type: none"> <li>Ethene</li> <li>Conc. H<sub>2</sub>SO<sub>4</sub> acts as a dehydrating agent.</li> <li><math>\text{C}_2\text{H}_5\text{OH} \xrightarrow[443 \text{ K}]{\text{Conc. H}_2\text{SO}_4 + \text{Heat}} \text{CH}_2 = \text{CH}_2 + \text{H}_2\text{O}</math></li> </ul>	½ ½  ½ ½  ½ ½  ½ ½  ½ ½  1  ½ ½  1	4
38	(a) Salivary glands; Starch / Carbohydrate (b) Stomach, Anus (c) <ol style="list-style-type: none"> <li>The inner lining of the stomach will not be protected from the action of acid.</li> <li>Digested food will not be absorbed. / Absorption area will be reduced</li> </ol>	½ + ½ ½ + ½  1 1	

	<b>OR</b>		
	<p>(c)</p> <ul style="list-style-type: none"> <li>• Emulsification of fats.</li> <li>• Acidic medium has to be made alkaline for the pancreatic enzymes to act.</li> </ul>	1 1	4
39	<p>(a)</p> <p>(i) Bulb A glows</p> <p>(ii) Bulbs B, C, D and E glow</p> <p>(b) <math>P = V \times I</math>  <math>11 = 55 \times I</math>  <math>I = \frac{1}{5} = 0.2 \text{ amp}</math></p> <p>(c)</p> <p>(i) Resistance of bulb B, <math>R = \frac{V}{I} = \frac{55 \text{ V}}{0.2 \text{ A}} = 275 \Omega</math></p> <p style="text-align: center;">(alternative formula for calculation <math>R = \frac{V^2}{P}</math>)</p> <p>(ii) Total resistance of the series combination of four bulbs  <math>= 4 \times 275 = 1100 \Omega</math></p> <p style="text-align: center;"><b>OR</b></p> <p>(c)</p> <ul style="list-style-type: none"> <li>• Bulb A will keep glowing with same brightness.</li> <li>• Other bulbs i.e., B, D and E will stop glowing.</li> </ul> <p><b>Reason :</b></p> <p>As the bulbs B, D and E are connected in series with fused bulb C, so no current flows through them and thus they will not glow. The bulb A remains unaffected as it is connected in parallel combination.</p>	½ ½  ½  1  1  ½ ½  1	4

\*\*\*\*\*